

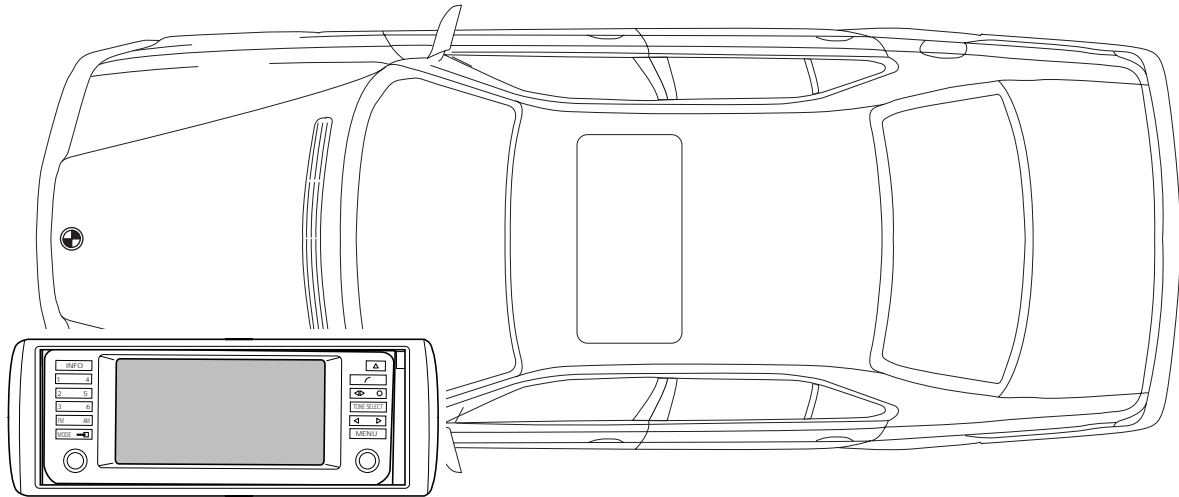

BMW Parts and Accessories Installation Instructions



F 38 0393 B

Retrofit Kit On-board Monitor and Navigation System

BMW 7 Series (E 38)

The installation instructions are only valid for vehicles which are equipped with OE 555 High on-board computer.

Technical and electrical knowledge is required
Installation time approx. 7 hours, which can vary according to the condition and fittings of the vehicle.

Retrofit/Installation Kit no. 65 90 0 025 170

Contents

Chapter	Page
1. Important notes on the installation of the on-board monitor and navigation system	48
2. Preparatory work	49
3. Parts overview	50
4. Connection overview	53
5. Installation and cabling diagram of the on-board monitor wiring harness	57
6. Installation and cabling diagram of the supplementary wiring harness for navigation	58
7. Install on-board monitor wiring harness, on-board monitor and on-board monitor radio	59
8. Install supplementary wiring harness for navigation in vehicles prior to production date 9/98	61
9. Choose installation of the supplementary wiring harness for navigation in vehicles from production date 9/98	66
10. Install supplementary wiring harness for navigation in vehicles from production date 9/98 (PIN18 and PIN35 at connector of the hydraulic unit ABS not assigned)	67
11. Install supplementary wiring harness for navigation in vehicles from production date 9/98 (PIN18 and PIN35 at connector of the hydraulic unit ABS assigned)	70
12. Install supplementary wiring harness for navigation in vehicles from production date 9/98 (PIN18 assigned and PIN35 not assigned at connector of the hydraulic unit ABS)	72
13. Install supplementary wiring harness for navigation in vehicles from production date 9/98 (PIN18 not assigned and PIN35 assigned at connector of the hydraulic unit ABS)	75
14. Install navigation system	78
15. Coding and finalising operations	83
16. Connection description for TV function	85
17. Circuit diagram, on-board monitor wiring harness	86
18. Circuit diagram, navigation system wiring harness	88
19. Circuit diagram, supplementary wiring harness for navigation system	90
20. Template for the installation of the navigation computer	92

1. Important notes on the installation of the on-board monitor and navigation system

Only for use within the BMW trading organisation.

Installation of the on-board monitor and the navigation system may only be undertaken by a specialist workshop which has available the necessary special tools and the required manuals (maintenance, repair, diagnostic, etc.).

When cables/leads are being installed, care should be taken to see that they do not get kinked or damaged.

Additionally installed cables/leads should if necessary be fastened with cable straps.

Item numbers relate only to the overviews or to the text at the side of the associated illustration.

All operations are represented as taking place on a left-hand drive vehicle, the same logical procedure must be followed for right-hand drive vehicles.

Electrical knowledge is required.



The function carrier for the on-board monitor and the on-board monitor radio are equipment-dependent and must be ordered separately in accordance with the Electronics Parts Catalogue (EPC).

The bracket for the video module does not form part of the installation kit and, for installation of a video module (TV function), must be ordered separately in accordance with the Electronic Parts Catalogue (EPC).

The control cable of the on-board monitor radio/CD changer does not form part of the installation kit and, for vehicles with CD changer without DSP amplifier, must be ordered separately in accordance with the Electronic Parts Catalogue (EPC).

The boot trim-panels at rear left do not form part of the installation kit and must be ordered separately in accordance with the Electronic Parts Catalogue (EPC) only for vehicles without TOP HiFi system and without CD changer (in vehicles with Top HiFi system or CD changer, the existing boot trim-panels at rear left can be cut). ◀

Rights are reserved to make technical modifications.

Required tools and auxiliary materials

MoDIC III or DIS

Set of 1/4 inch socket wrenches

Set of Phillips screwdrivers

Cable lamp

Side-cutting pliers

Silicone

Hot air dryer

Set of Torx socket wrenches

Set of flat-tip screwdrivers

Multimeter

Short Phillips screwdriver

2. Preparatory work

	TIS AW NO.
Print out error memory	
Disconnect battery	12 00 ...
Dismantle finisher of instrument panel, centre left	51 45 030
Dismantle finisher of instrument panel, right	51 45 030
Dismantle radio (no longer required)	65 11 030
Dismantle operating unit for Top HiFi system or coin compartment (no longer required)	65 12 040
Dismantle multi-information display (no longer required)	65 81 010
Dismantle air conditioning operating unit	64 11 750
Dismantle individual control switches or switch panels in the function carrier	64 11 750
Dismantle function carrier of radio, is to be replaced by function carrier of on-board monitor	51 16 202
Re-mount can holder, front	51 16 202
Dismantle facing centre console, front left	51 16 239
Undo centre console, below front left	51 16 239
Dismantle left front seat	52 17 000
Dismantle rear seat bench	52 24 005
Dismantle rear seat back	52 24 015
Dismantle sill strip, left front and left rear	51 47 000/51 47 030
Dismantle lower part of the B-pillar trim panel, left	
Fold up carpet on left	
Dismantle C-pillar trim panel on left and right	51 43 251
Dismantle rear window shelf	51 46 000
Dismantle boot floor	51 47 101
Dismantle entire side trim panel in boot on left	51 47 151
Dismantle rear side trim panel in boot on right	51 47 172
Dismantle trim panel of closing panel	51 46 050
Dismantle sill strip at right front and right rear	51 47 000/51 47 030
Dismantle lower part of the B-pillar trim panel, right	
Dismantle A-pillar trim panel, lower right	
Dismantle glove box	51 16 360
Dismantle footwell trim panel in front of glove box	
Fold up carpet on right	
Dismantle CD changer (if exists)	65 11 070
Dismantle bracket for CD changer (if exists)	
Dismantle telephone components with supports (if they exist)	
Dismantle DSP amplifier (if exists)	65 11 070
Dismantle bracket for DSP amplifier (if exists)	65 11 070

In addition for right-hand drive vehicles

	TIS AW No.
Dismantle footwell trim panel under the steering column	

3. Parts overview

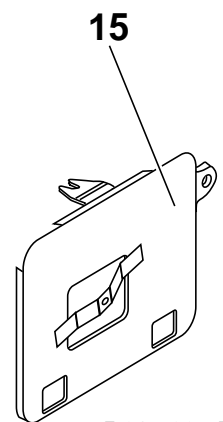
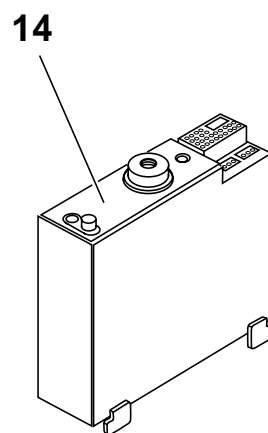
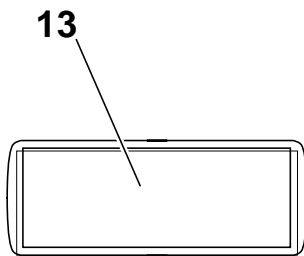
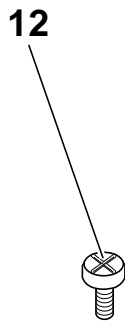
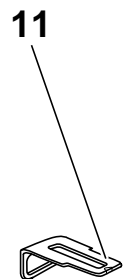
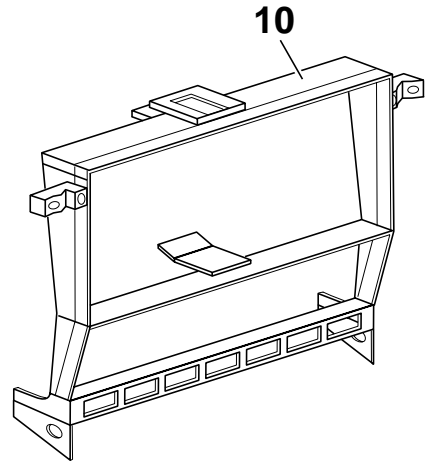
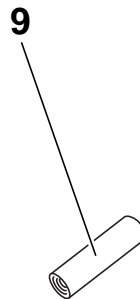
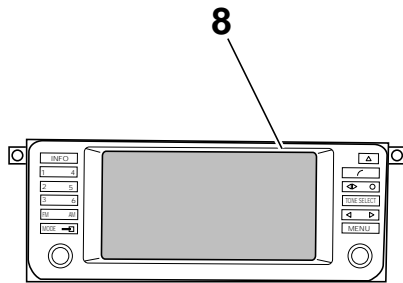
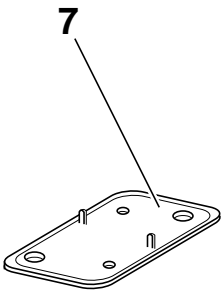
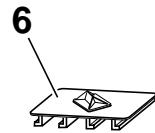
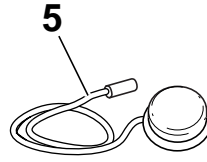
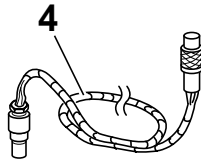
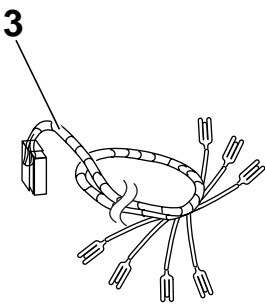
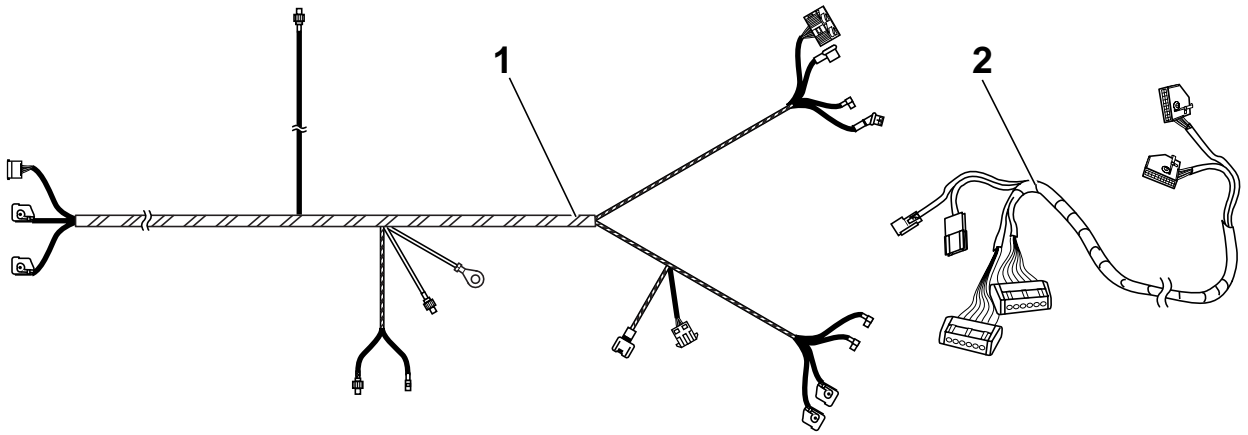

F 38 0395 B

3. Parts overview

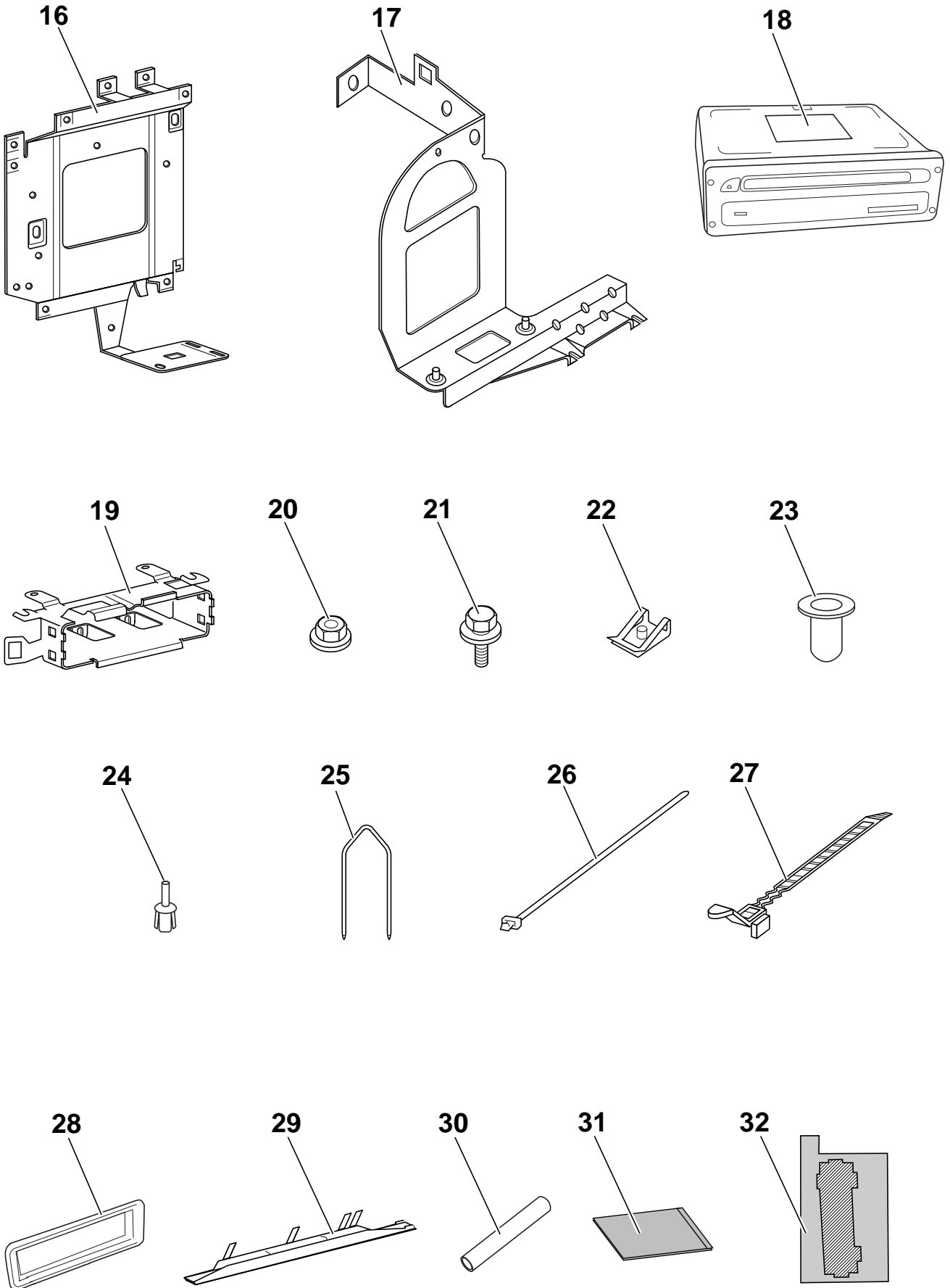

F 38 0394 B

3. Parts overview

- 1 On-board monitor wiring harness
- 2 Navigation wiring harness
- 3 Supplementary wiring harness for navigation system
- 4 Antenna extension for GPS antenna
- 5 GPS antenna
- 6 Mounting clip
- 7 Bracket of GPS antenna
- 8 Complete on-board monitor
- 9 On-board monitor holding pin (for supporting the on-board monitor)
- 10 Function carrier of on-board monitor
- 11 Retaining clip of on-board monitor
- 12 Cross-recess fillister head screw M3x8 (4 items)
- 13 Cover for on-board monitor
- 14 On-board monitor radio*
- 15 On-board monitor radio bracket
- 16 Basic carrier
- 17 Bracket of video module
- 18 Navigation computer
- 19 Bracket of navigation computer
- 20 Hex nut with washer M5
- 21 Hexagon bolt with washer M5x14 (12 items)
- 22 Plug-in nut M5 (9 items)
- 23 Bush (for attachment of the bracket of the GPS antenna) (2 items)
- 24 Expanding rivet (for attaching the GPS antenna) (2 items)
- 25 Disassembly clip (2 items)
- 26 Cable strap (20 items)
- 27 AW cable strap (2 items)
- 28 Cover frame
- 29 Cable duct
- 30 Shrinkage tubing (contained in the supplied package of the supplementary wiring harness for navigation system) (4 items)
- 31 Protective strip (2 items)
- 32 Template (for installation of the navigation computer)

The parts marked with a * are not included in the parts kit and must be ordered separately in each case in accordance with the vehicle equipment and with reference to the Electronic Parts Catalogue (EPC).

4. Connection overview

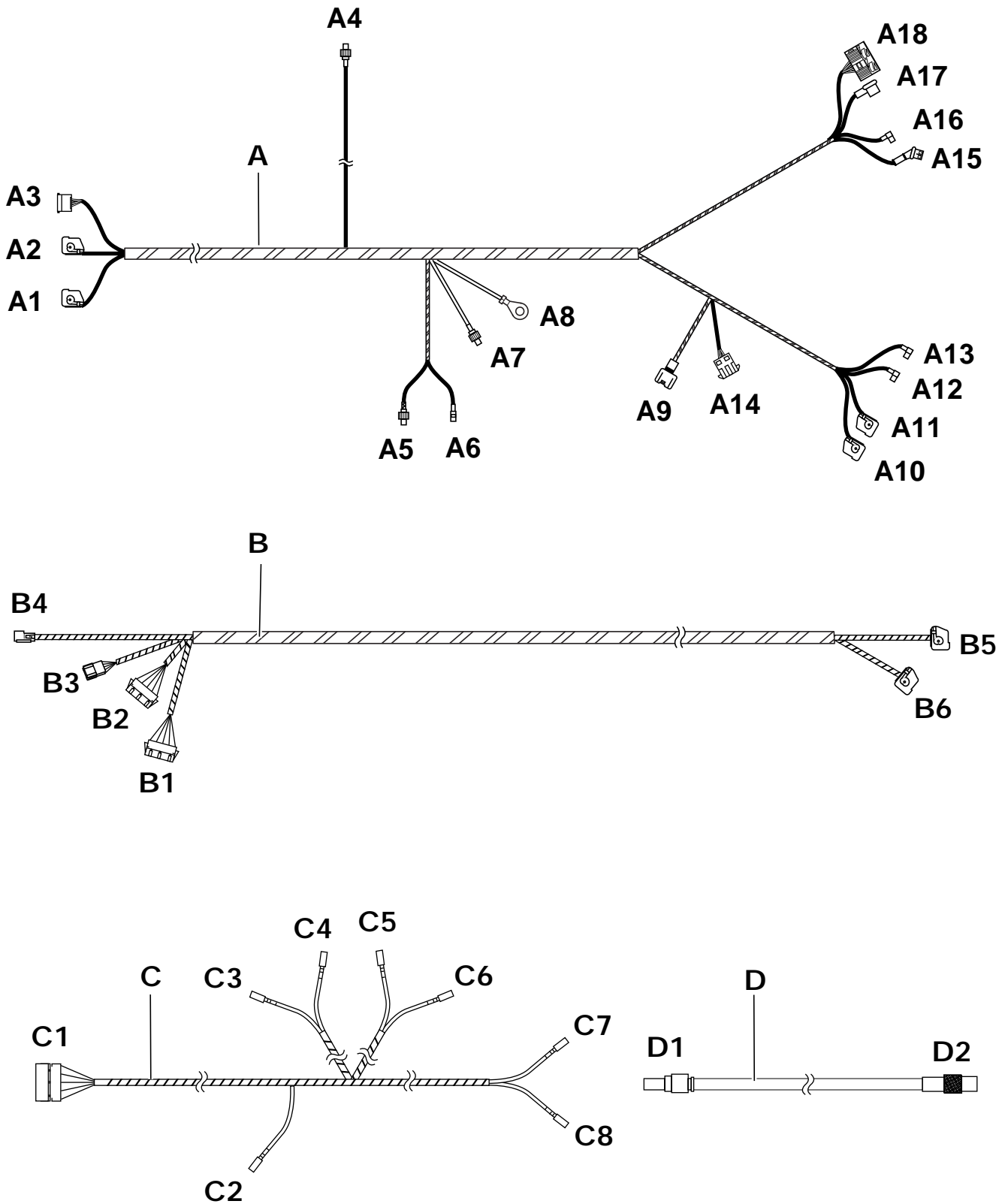

4. Connection overview

Item	Designation	Cable colour	Connection point in vehicle
A	On-board monitor wiring harness	-	-
A1	blue 12-pole socket housing	-	at blue 12-pole pin housing at on-board monitor (8)
A2	white 12-pole socket housing	-	at white 12-pole pin housing at on-board monitor (8)
A3	black 17-pole pin housing	-	at black 17-pole radio connector X18126
A4	coaxial pin housing	black	is installed to installation location of the right TV amplifier in the C-pillar on the right and tied back
A5	coaxial pin housing	black	at coaxial socket housing at antenna diversity
A6	coaxial socket housing	black	at coaxial pin housing at antenna diversity
A7	coaxial pin housing	black	is installed to installation location of the left TV amplifier in the C-pillar on the left and tied back
A8	ring terminal Ø6 mm	brown	at ground post X13016 at the C-pillar left
A9	black 10-pole pin housing	-	at branch cable B4 , black 10-pole socket housing, of the navigation wiring harness B
A10	white 18-pole socket housing	-	is tied back with cable strap at on-board monitor wiring harness A
A11	blue 18-pole socket housing	-	at blue 18-pole pin housing at navigation computer (18)
A12	angled coaxial socket housing	black	is tied back with cable strap at on-board monitor wiring harness A
A13	angled coaxial socket housing	black	is tied back with cable strap at on-board monitor wiring harness A
A14	natural coloured 6-pole pin housing	-	at branch cable B1 , natural coloured 6-pole socket housing, of the navigation wiring harness B
A15	10-pole socket housing	-	is clipped into black 17-pole socket housing A18 of the on-board monitor wiring harness A and plugged in with the black 17-pole socket housing A18 of the on-board monitor radio (14)
A16	angled coaxial socket housing	black	at coaxial pin housing at on-board monitor radio (14)
A17	black coaxial socket housing (antenna connection)	black	at coaxial pin housing at on-board monitor radio (14) (antenna connection)
A18	black 17-pole socket housing	-	at on-board monitor radio (14)

4. Connection overview

Item	Designation	Cable colour	Connection point in vehicle
B	Navigation wiring harness	-	-
B1	natural coloured 6-pole socket housing	-	at branch cable A14 , natural coloured 6-pole pin housing of the on-board monitor wiring harness A
B2	black 6-pole socket housing	-	at branch cable C1 , black 6-pole pin housing of the supplementary wiring harness for navigation C
B3	black 6-pole pin housing	-	In vehicles equipped with Basis-Interface Telephone 2 (BIT2), plug together branch cable B3 , black 6-pole pin housing, of the navigation wiring harness B , with the black 6-pole socket housing of the Basis-Interface Telephone wiring harness (BIT2).
			In vehicles without Basis-Interface Telephone 2 (BIT2), insulate and tie back branch cable B3 , black 6-pole pin housing, of the navigation wiring harness B .
B4	black 10-pole socket housing	-	at branch cable A9 , black 10-pole pin housing, of the on-board monitor wiring harness A
B5	blue 18-pole socket housing	-	is tied back with cable strap to the navigation wiring harness B
B6	Bordeaux-coloured 18-pole socket housing	-	at Bordeaux-coloured 18-pole pin housing at navigation computer (18)

C	Supplementary wiring harness for navigation	-	-
C1	black 6-pole pin housing	-	at branch cable B2 , black 6-pole socket housing, of the navigation wiring harness B
C2	1-pole blade terminal contact	white/yellow	at light module X10117 in black 54-pole socket housing, PIN38
C3	1-pole blade terminal contact	yellow/red	In vehicles prior to production date 9/98 insulate with shrinkage tubing and tie back
			In vehicles from production date 9/98 at joint connector X10183 (cable colour at joint connector yellow/red), in case C3 is not required, insulate with shrinkage tubing and tie back, in LHD vehicles tie back excess length
C4	1-pole blade terminal contact	yellow/white	In vehicles prior to production date 9/98 insulate with shrinkage tubing and tie back
			In vehicles from production date 9/98 at joint connector X10184 (cable colour at joint connector yellow/white), should C3 not be required, insulate with shrinkage tubing and tie back, in LHD vehicles tie back excess length

4. Connection overview

Item	Designation	Cable colour	Connection point in vehicle
C5	1-pole blade terminal contact	yellow/red	In vehicles prior to production date 9/98 at connector X1171 of the ABS control unit in PIN9 , in LHD vehicles tie back excess length
			In automatic vehicles with M62 B44 engine and DSC, from production date 9/97 to production date 9/98 at connector X1171 of the ABS control unit in PIN72 , in LHD vehicles tie back excess length
			In vehicles from production date 9/98 insulate with shrinkage tubing and tie back
C6	1-pole blade terminal contact	yellow/white	In vehicles prior to production date 9/98 at connector X1171 of the ABS control unit in PIN42 , in LHD vehicles tie back excess length
			In automatic vehicles with M62 B44 engine and DSC, from production date 9/97 to production date 9/98 at connector X1171 of the ABS control unit in PIN73 , in LHD vehicles tie back excess length
			In vehicles from production date 9/98 insulate with shrinkage tubing and tie back
C7	1-pole blade terminal contact	yellow/red	In vehicles prior to production date 9/98 insulate with shrinkage tubing and tie back
			In vehicles from production date 9/98 at black 42-pole connector X1170 of the hydraulic unit ABS in PIN35 , should C7 not be required, insulate with shrinkage tubing and tie back
C8	1-pole blade terminal contact	yellow/white	In vehicles prior to production date 9/98 insulate with shrinkage tubing and tie back
			In vehicles from production date 9/98 at black 42-pole connector X1170 of the hydraulic unit ABS in PIN18 , should C8 not be required, insulate with shrinkage tubing and tie back

D	Antenna extension for GPS antenna	-	-
D1	Coaxial pin housing	-	at GPS antenna (5)
D2	Coaxial socket housing	-	at navigation computer (18)

5. Installation and cabling diagram of the on-board monitor wiring harness

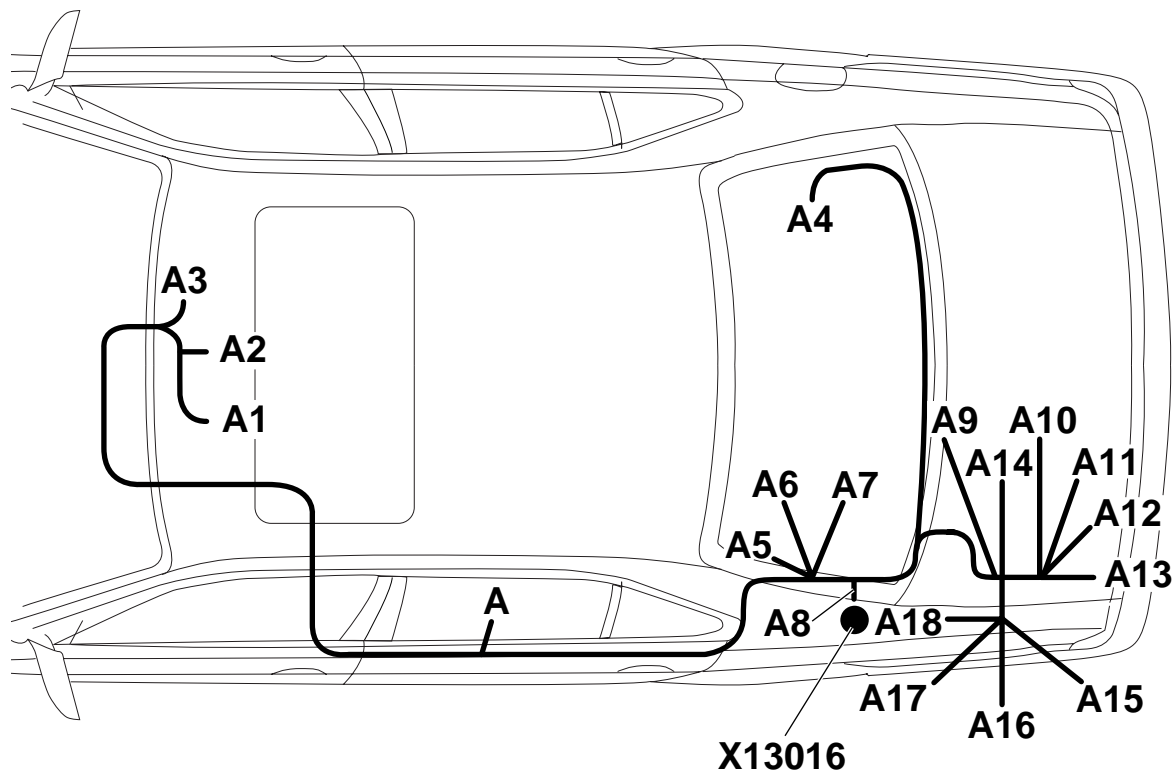

F 38 0398 B

The on-board monitor wiring harness **A** is, as shown, to be installed along the audio or main wiring harness and to be fastened with cable straps.

When installing the on-board monitor wiring harness A, you should begin at the ground post X13016 in the area of the C-pillar at rear left.

Branch cable **A8**, screw on at ground post **X13016** in the area of the C-pillar, rear left
On-board monitor wiring harness **A** traverses behind the left front seat and from there is installed along the gearbox tunnel behind the centre console to the installation location of the on-board monitor.

Branch cable **A4** to the installation location of the right-hand side TV amplifier at the C-pillar, right (is only connected in association with the installation kit of a video module and the TV amplifiers)

Branch cable **A5** and **A6** to the antenna amplifier at the C-pillar, left.

Branch cable **A7** to the installation location of the left TV amplifier at the C-pillar left (is only connected in association with the installation kit of a video module and the TV amplifiers)

Branch cable **A1**, **A2** and **A3** along the series audio wiring harness to the installation location of the on-board monitor in the I-panel

Branch cables **A9** to **A18** through the opening in the rear window shelf along the main cable loom in the boot

Install branch cable **A9** to the installation location of the video module bracket in the side part, rear left and clip into branch cable **A14**

Branch cables **A10** to **A13** to the installation location of the navigation computer in the side part, rear left

Tie back branch cables **A10**, **A12** and **A13** (they are only connected in association with the installation of a video module and the TV amplifiers)

Install branch cable **A14** to the installation location of the video module bracket in the side part, rear left and snap in with clipped-in branch cable **A9** at mounting clip

Branch cables **A15** to **A18** to the installation location of the on-board monitor radio in the side part, rear left.

Any excessive lengths should be tied back

6. Installation and cabling diagram of the supplementary wiring harness for navigation

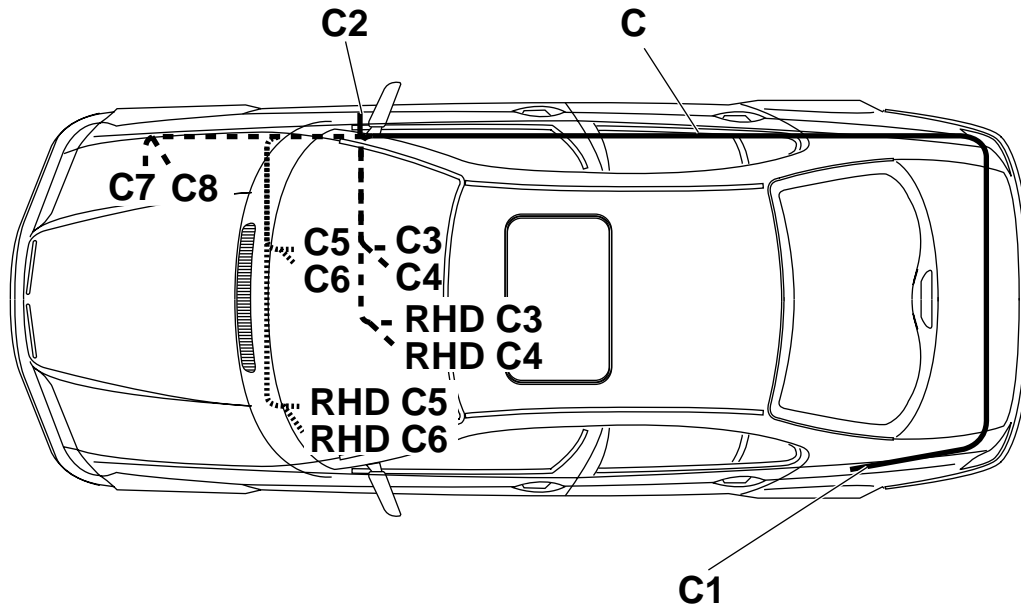

F 38 0399 B

The supplementary wiring harness for navigation **C** should be installed as shown and fastened with cable straps.

When installing the supplementary wiring harness for Navigation **C, you should begin with branch cable **C1**.**

Key:

- Installation in all vehicles
- - - - - Additional installation for vehicles from production date 9/98
- Additional installation for vehicles prior to production date 9/98

Branch cable **C1** to taillight cup in boot, rear left

Branch cable **C2** to **C8** along the closing panel to the right side part, from there through the lead-through grommet in the rear window shelf into the vehicle interior and from there along the right main cable loom to the installation location of the light module

Branch cable **C3** and **C4** to the joint connector behind the glove box

Branch cable **C5** and **C6** to the installation location of the ABS control unit behind the glove box

Branch cable **C7** and **C8** through the lead-through grommet in the bulkhead into the engine compartment to the installation location of the hydraulic unit ABS

Tie back any excess lengths

7. Install on-board monitor wiring harness, on-board monitor and on-board monitor radio

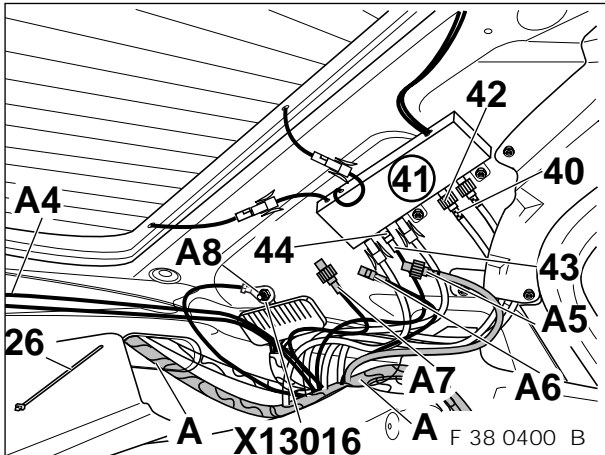

Screw branch cable **A8**, ring terminal \varnothing 6 mm, of the on-board monitor wiring harness **A**, to the ground post **X13016** at the C-pillar, rear left.

Tie back branch cable **A7**, coaxial pin housing, of the on-board monitor wiring harness **A**, with cable strap (26) (is only connected in association with the installation of a video module).

Screw off existing coaxial pin housing (40) of the antenna amplifier (41) and tie it back (is no longer required).

Screw branch cable **A5**, coaxial pin housing, of the on-board monitor wiring harness **A**, onto the freed coaxial socket housing (42) of the antenna amplifier (41).

Unpin existing coaxial socket housing (43) of the antenna amplifier (41) and tie it back (is no longer required).

Plug branch cable **A6**, coaxial socket housing, of the on-board monitor wiring harness **A**, on to the freed coaxial pin housing (44) of the antenna amplifier (41).

Install branch cable **A4**, coaxial pin housing, of the on-board monitor wiring harness **A**, on the rear window shelf along the rear window to the installation location of the right TV amplifier to the C-pillar on the right and tie it back with cable straps (26) (is only connected in association with the installation of a video module).

7. Install on-board monitor wiring harness, on-board monitor and on-board monitor radio

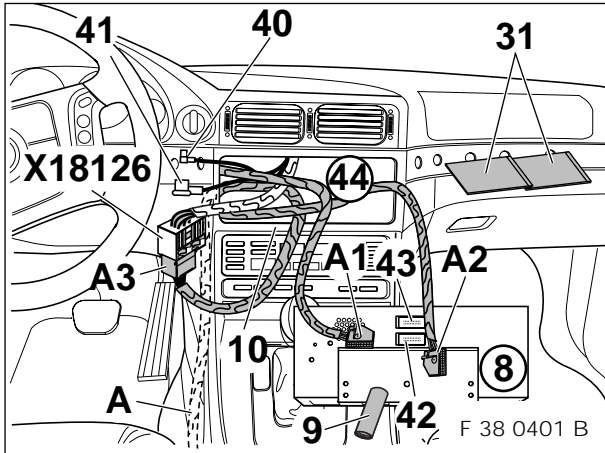

! Before the work steps are carried out as shown in the illustration, the new function carrier of the on-board monitor (10) must be fitted and equipped as described in the TIS. ◀

Plug together branch cable **A3**, black 17-pole pin housing, of the on-board monitor wiring harness **A**, with the existing black 17-pole socket housing **X18126**. Stick one rattle protector (31) onto the second rattle protector (31) and then stick it onto the wiring harness in such a way that the existing angled coaxial socket housing (40), the black coaxial socket housing (41) (antenna connection), the connector of the multi information display, and the operating unit for the Top HiFi system (if present), and the plug-in connector **A3+X18126** are enclosed.

The enclosed connections, as well as the enclosed plug-in connector **A3+X18126** are no longer required and should be placed behind the heating and ventilation operating unit. Screw on-board monitor holding pin (9) on to the on-board monitor (8).

Plug branch cable **A1**, blue 12-pole socket housing, of the on-board monitor wiring harness **A**, onto the blue 12-pole pin housing (42) of the on-board monitor (8).

Plug branch cable **A2**, white 12-pole socket housing, of the on-board monitor wiring harness **A**, onto the white 12-pole pin housing (43) of the on-board monitor (8).

Then feed the cables into the on-board monitor cavity (44) and carefully push in the on-board monitor (8).

When pushing the on-board monitor in, make sure that no cables become damaged.

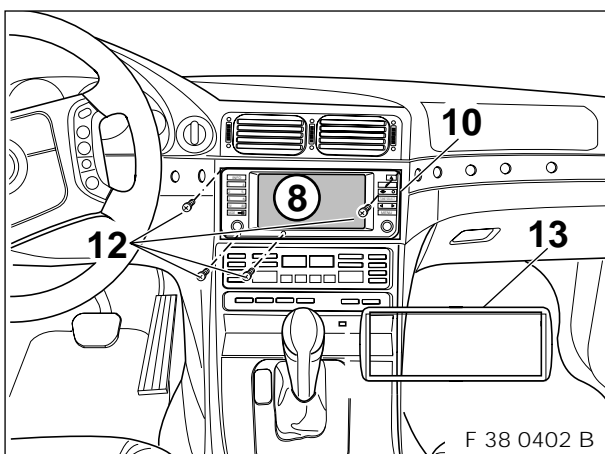

Screw on-board monitor (8) to the function carrier of the on-board monitor (8) with four crossed recessed raised cheese head screws M3x8 (12).

Then put the cover for the on-board monitor (13) onto the on-board monitor (8).

7. Install on-board monitor wiring harness, on-board monitor and on-board monitor radio

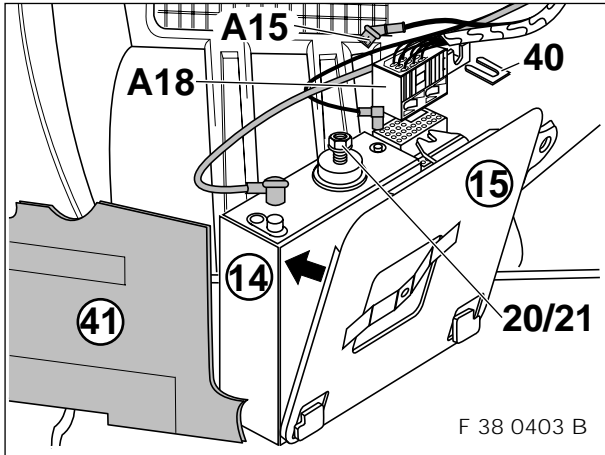

▶ Illustration shows boot, rear left. ◀

Couple the on-board monitor radio bracket (15) into the on-board monitor radio (14) below and screw it on above with a hex nut with washer M5 (20) or with a hexagon bolt with washer M5x14 (24), depending on the design of the on-board monitor radio (14).

Remove blue locking clamp (40) from the black 17-pole socket housing **A18** and plug in branch cable **A15**, 10-pole socket housing, of the on-board monitor wiring harness **A**, at the designated place in the black 17-pole socket housing **A18**.

In vehicle with CD changer without DSP amplifier, the control cable of the on-board monitor radio/CD changer will have to be fitted additionally.

Secure branch cable **15**, 10-pole socket housing, with the blue locking clamp (40). Then detach the insulating mat (41) in the side part, inside rear left.

7. Install on-board monitor wiring harness, on-board monitor and on-board monitor radio

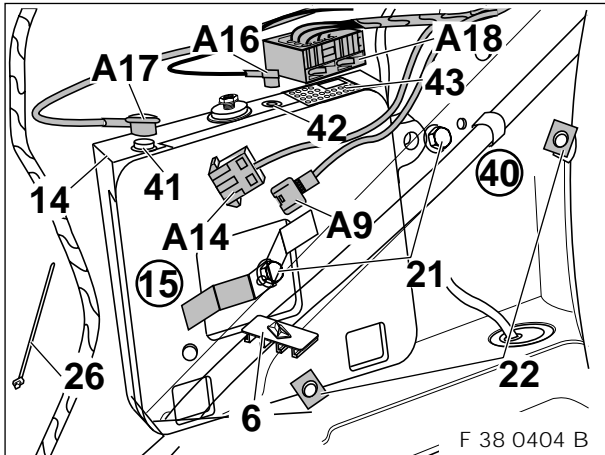

Screw the on-board monitor radio bracket (15) with attached on-board monitor radio (14) on to the cross-brace (40) in the side part, rear left, with two hexagon bolts with washers M5x14 (2). Plug branch cable **A17**, black coaxial socket housing, (antenna connection), of the on-board monitor wiring harness **A**, onto the coaxial pin housing (41) at the on-board monitor radio (14). Plug branch cable **A16**, angled coaxial socket housing, of the on-board monitor wiring harness **A**, on to the coaxial pin housing (42) at the on-board monitor radio (14).

Plug branch cable **A18**, black 17-pole socket housing, of the on-board monitor wiring harness **A**, onto the black 17-pole pin housing (43) at the on-board monitor radio (14). The cables of the plugged-in branch cables **A16**, **A17** and **A18** should be fastened with cable straps (26).

Put two plug-in nuts M5 (22) on to the pre-punched holes in the cross-brace (40) in the side part, rear left and mount the detached insulating mat again in the side part, rear left.

Clip in branch cable **A9**, black 10-pole pin housing, of the on-board monitor wiring harness **A**, into branch cable **A14**, natural-coloured 6-pole pin housing, of the on-board monitor wiring harness **A**.

Then clip in the mounting clip (6) into branch cable **A14**, natural-coloured 6-pole pin housing (is later snapped into the bracket of the video module).

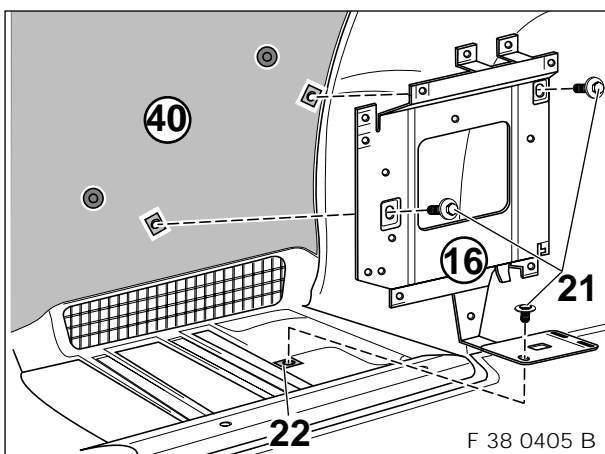

Put a plug-in nut M5 (22) on to the designated plate in the side part, rear left. Screw the basic carrier (16) onto the three plug-in nuts M5 with three hexagon bolts with washers M5x15 (21), as shown in the illustration.

▶ Take care to see that the insulating mat (40) is mounted first. ◀

8. Install supplementary wiring harness for navigation in vehicles prior to production date 9/98

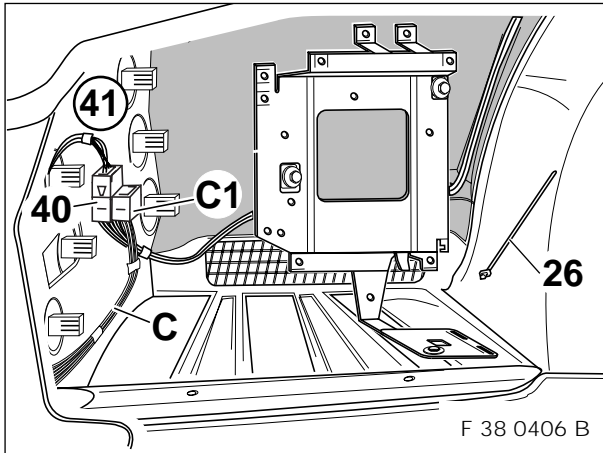

Clip in branch cable C1, black 6-pole pin housing, of the supplementary wiring harness for navigation **C**, to the existing plug-in connector (40) at the taillight cup (41), rear left. Install supplementary wiring harness for navigation **C** along the closing panel to the right side part. Fasten supplementary wiring harness for navigation **C** with cable straps (26).

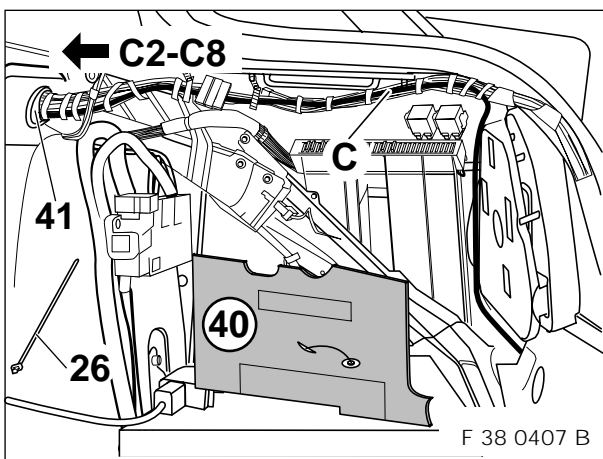

Dismantle insulating mat (40) in the right side part, rear. Install supplementary wiring harness for navigation **C**, as shown, to the lead-through grommet (41) in the rear window shelf. Then install branch cables **C2** to **C8** through the lead-through grommet (41) into the vehicle interior and from there along the right main cable loom to the installation location of the light module in the A-pillar on the right. Fasten supplementary wiring harness for navigation **C** with cable straps (26) and install insulating mat (40) again in the right side part, rear.

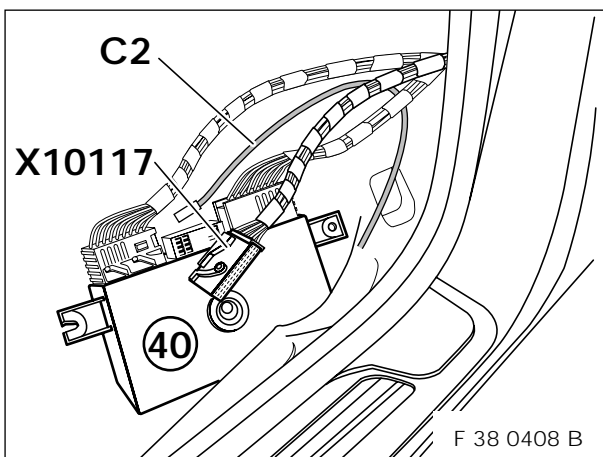

Dismantle light module (40), unpin the black 54-pole socket housing **X10117** from the light module (40) and open it. Plug in branch cable **C2**, 1-pole blade terminal contact, cable colour white/yellow, into **PIN38** of the black 54-pole socket housing **X10117**. Close black socket housing **X10117**, plug it in and reinstall light module (40). If necessary tie back excessive length of the supplementary wiring harness for navigation **C** before branch cable **C2**.

8. Install supplementary wiring harness for navigation in vehicles prior to production date 9/98

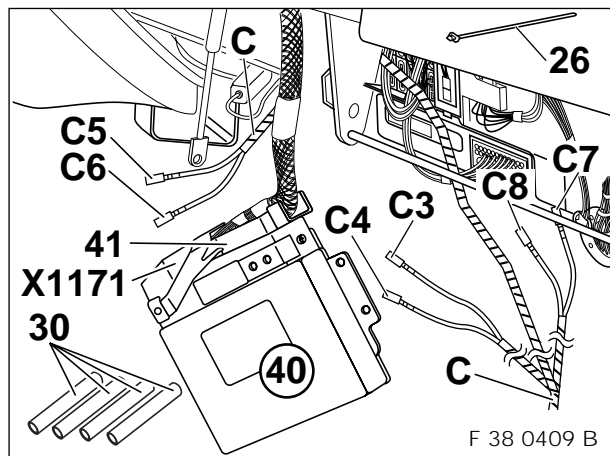

▶ Illustration shows installation in a left-hand drive vehicle. You should proceed in the identical logical sequence for right-hand drive vehicles. ◀

Push on shrinkage tubing (30) for insulation in each case onto branch cable **C3**, 1-pole blade terminal contact, cable colour yellow/red, branch cable **C4**, 1-pole blade terminal contact, cable colour yellow/white, branch cable **C7**, 1-pole blade terminal contact, cable colour yellow/red and branch cable **C8**, 1-pole blade terminal contact, cable colour yellow/white, of the supplementary wiring harness for navigation **C**, and shrink them on with a hot-air dryer.

Then tie back with cable straps (26) branch cables **C3**, **C4**, **C7** and **C8** in the area of the right front sill.

In left-hand drive vehicles, install branch cables **C5** and **C6** of the supplementary wiring harness for navigation **C** to the ABS control unit (40) on the left by the side of the glove box (excess length must be tied back).

In right-hand drive vehicles, install branch cables **C5** and **C6** from the supplementary wiring harness for navigation **C** behind the heater box towards the left to the ABS control unit on the right by the side of the glove box.

Dismantle ABS control unit (40).

Unpin control unit connector **X1171** and dismantle it.

Insert branch cable **C5** and **C6** into the plug-in guide (41).

▶ **Note instructions for automatic cars with M62 B44 engine and DSC, from production date 9/97 to production date 9/98 on the next page.** ◀

Plug in branch cable **C5**, 1-pole blade terminal contact, cable colour yellow/red, in **PIN9** of the control unit connector **X1171**. If **PIN9** is already assigned, the contact of branch cable **C5** must be cut off and the yellow/red cable in the space of the ABS connector must be soldered to the cable of **PIN9** and insulated.

Plug in branch cable **C6**, 1-pole blade terminal contact, cable colour yellow/white, in **PIN42** of the control unit connector **X1171**. If **PIN42** is already assigned, the contact of branch cable **C6** must be cut off and the yellow/white cable in the space of the ABS connector must be soldered to the cable of **PIN42** and insulated.

Reassemble control unit connector **X1171** and plug it onto the ABS control unit (40). Install ABS control unit (40) and fasten supplementary wiring harness for navigation **C** with cable straps (26).

8. Install supplementary wiring harness for navigation in vehicles prior to production date 9/98

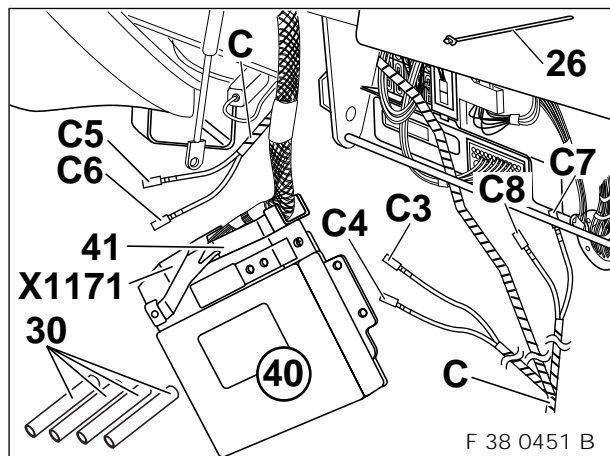

Only for automatic cars with M62 B44 engine and DSC, from production date 9/97 to production date 9/98

Plug in branch cable **C5**, 1-pole blade terminal contact, cable colour yellow/red, in **PIN72** of the control unit connector **X1171**. If **PIN72** is already assigned, the contact of branch cable **C5** must be cut off and the yellow/red cable in the space of the ABS connector must be soldered to the cable of **PIN72** and insulated.

Plug in branch cable **C6**, 1-pole blade terminal contact, cable colour yellow/white, in **PIN73** of the control unit connector **X1171**. If **PIN73** is already assigned, the contact of branch cable **C6** must be cut off and the yellow/white cable in the space of the ABS connector must be soldered to the cable of **PIN73** and insulated.

Reassemble control unit connector **X1171** and plug it onto the ABS control unit (40).

Install ABS control unit (40) and fasten supplementary wiring harness for navigation **C** with cable straps (26).

9. Choose installation of the supplementary wiring harness for navigation in vehicles from production date 9/98

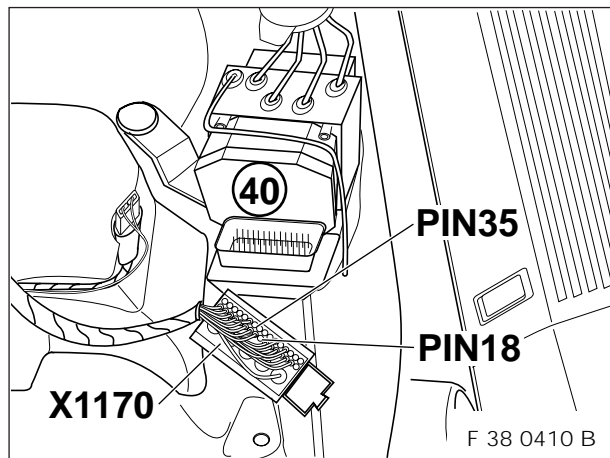

▶ Illustration shows engine compartment, front right. ◀

Unplug the black 42-pole connector **X1170** from the hydraulic unit ABS (40) in the engine compartment, front right. Open it and check whether **PIN18** and **PIN35** are assigned.

If **PIN18** and **PIN35** are not assigned, installation of the supplementary wiring harness for navigation should be carried out as described in **Chapter 10**.

Chapter 10. Install supplementary wiring harness for navigation in vehicles from production date 9/98 (PIN18 and PIN35 at connector of the ABS hydraulic unit not assigned).

If **PIN18** and **PIN35** are assigned, installation of the supplementary wiring harness for navigation should be carried out as described in **Chapter 11**.

Chapter 11. Install supplementary wiring harness for navigation in vehicles from production date 9/98 (PIN18 and PIN35 at connector of the ABS hydraulic unit assigned)

If **PIN18** is assigned and **PIN35** not assigned, installation of the supplementary wiring harness for navigation should be carried out as described in **Chapter 12**.

Chapter 12. Install supplementary wiring harness for navigation in vehicles from production date 9/98 (PIN18 assigned and PIN35 not assigned at connector of the ABS hydraulic unit).

If **PIN18** is not assigned and **PIN35** assigned, installation of the supplementary wiring harness for navigation should be carried out as described in **Chapter 13**.

Chapter 13. Install supplementary wiring harness for navigation in vehicles from production date 9/98 (PIN18 not assigned and PIN35 assigned at connector of the ABS hydraulic unit)

10. Install supplementary wiring harness for navigation in vehicles from production date 9/98 (PIN18 and PIN35 at connector of the ABS hydraulic unit not assigned)

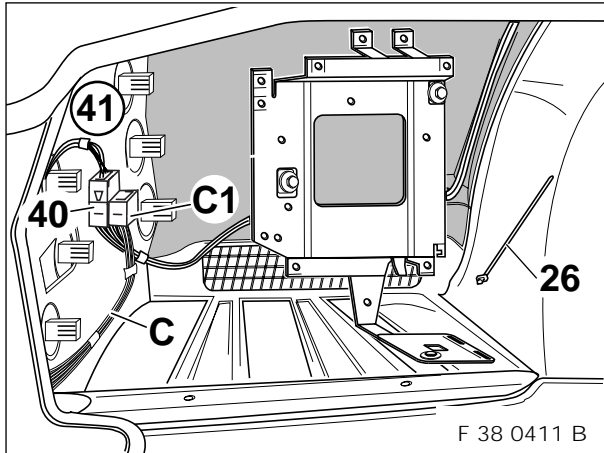

Clip in branch cable **C1**, black 6-pole pin housing, of the supplementary wiring harness for navigation **C** to the existing plug-in connector (40) at the taillight cup (41), rear left. Install supplementary wiring harness for navigation **C** along the closing panel to the right side part. Fasten supplementary wiring harness for navigation **C** with cable straps (26).

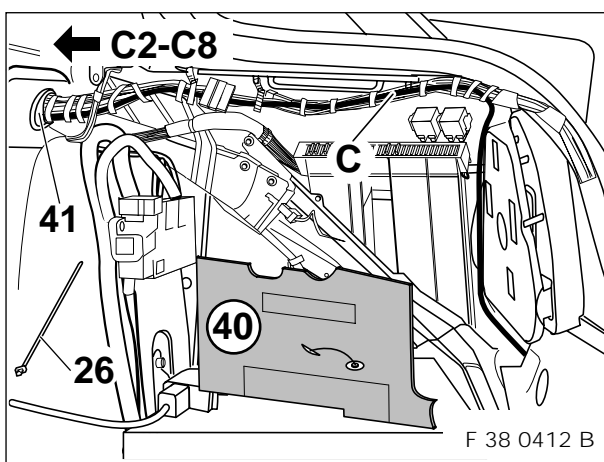

Dismantle insulating mat (40) in the right side part, rear. Install supplementary wiring harness for navigation **C**, as shown, to the lead-through grommet (41) in the rear window shelf. Then install branch cables **C2** to **C8** through the lead-through grommet (41) into the vehicle interior and from there along the right main cable loom to the installation location of the light module in the A-pillar on the right. Fasten supplementary wiring harness for navigation **C** with cable straps (26) and install insulating mat (40) again in the right side part, rear.

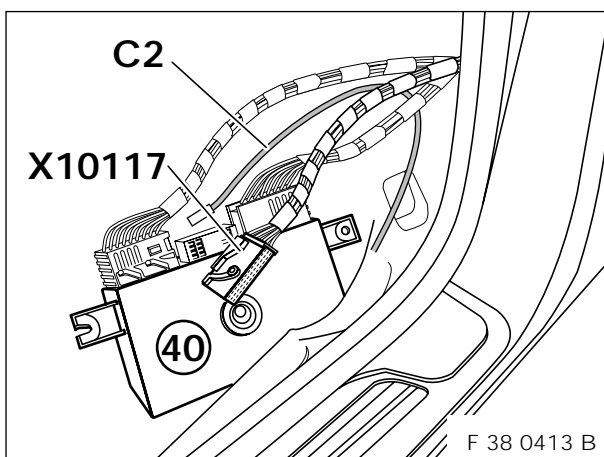

Dismantle light module (40), unpin the black 54-pole socket housing **X10117** from the light module (40) and open it. Plug in branch cable **C2**, 1-pole blade terminal contact, cable colour white/yellow, into **PIN38** of the black 54-pole socket housing **X10117**. Close black socket housing **X10117**, plug it in and reinstall light module (40). If necessary tie back excessive length of the supplementary wiring harness for navigation **C** before branch cable **C2**.

10. Install supplementary wiring harness for navigation in vehicles from production date 9/98 (PIN18 and PIN35 at connector of the ABS hydraulic unit not assigned)

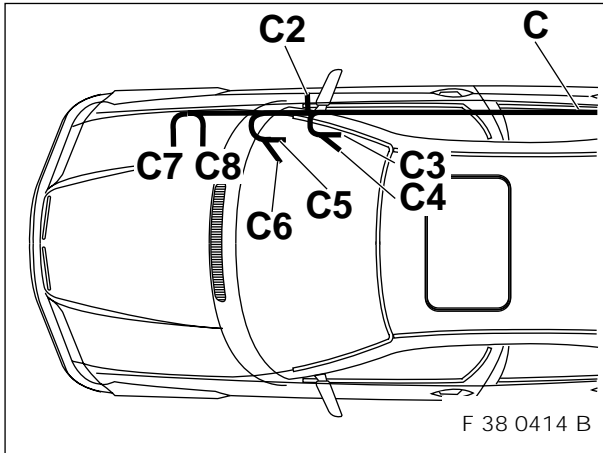

! Before further installation of the supplementary wiring harness for navigation is undertaken, the cover for the control unit box in the engine compartment, right, should be removed. ◀

Insulate branch cables **C3** to **C6** of the supplementary wiring harness for navigation **C** with shrinkage tubing and tie back in the area of the right front sill.

Install branch cables **C7** and **C8** of the supplementary wiring harness for navigation **C** through the lead-through grommet in the bulkhead, front right, into the control unit box and from there onwards to the hydraulic unit ABS and connect them to the black 42-pole connector **X1170** of the hydraulic unit ABS.

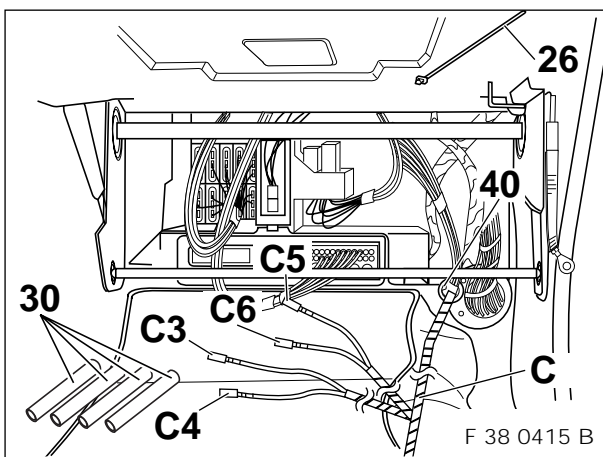

▶ Illustration shows the area behind the glove box in a left-hand drive vehicle. You should proceed in the identical sequence for right-hand drive vehicles. ◀

Feed the supplementary wiring harness for navigation **C** with branch cables **C7** and **C8** through the lead-through grommet (40) in the bulkhead, front right, to the control unit box in the engine compartment and fasten with cable straps (26).

Push on a shrinkage tubing (30) for insulation in each case onto branch cable **C3**, 1-pole blade terminal contact, cable colour yellow/red, branch cable **C4**, 1-pole blade terminal contact, cable colour yellow/white, branch cable **C5**, 1-pole blade terminal contact, cable colour yellow/red, and branch cable **C6**, 1-pole blade terminal contact, cable colour yellow/white, of the supplementary wiring harness for navigation **C**, and shrink them on with hot-air dryer.

Then tie back branch cables **C3** to **C6** in the area of the right front sill with cable straps (26).

10. Install supplementary wiring harness for navigation in vehicles from production date 9/98 (PIN18 and PIN35 at connector of the ABS hydraulic unit not assigned)

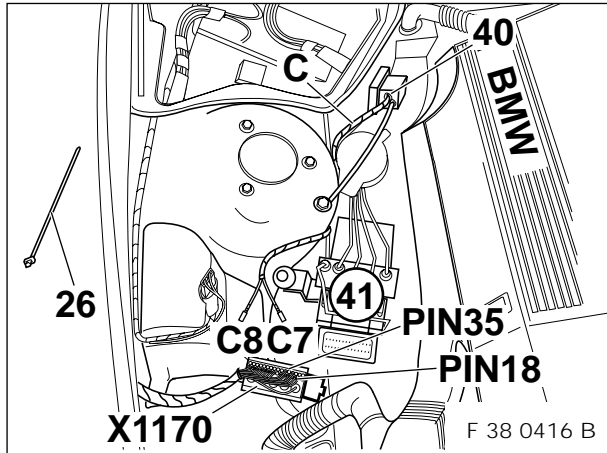

Push supplementary wiring harness for navigation **C** with branch cables **C7** and **C8** carefully through the rubber grommet (40) and install to the hydraulic unit ABS (41).

▶ Having installed the supplementary wiring harness for navigation **C**, seal the rubber grommet (40) with silicon (splash-water protection). ◀

Decouple the black 42-pole connector **X1170** of the hydraulic unit ABS and connect branch cables **C7** and **C8** as follows:

Pin in branch cable **C7**, 1-pole blade terminal contact, cable colour yellow/red, into the black 42-pole connector **X1170** of the hydraulic unit ABS in plug-in place **PIN35**.

Pin in branch cable **C8**, 1-pole blade terminal contact, cable colour yellow/white, into the black 42-pole connector **X1170** of the hydraulic unit ABS in plug-in place **PIN18**.

Couple black 42-pole connector **X1170** again and plug onto hydraulic unit ABS.

Then fasten supplementary wiring harness for navigation **C** in the area of the engine compartment with cable straps (26).

11. Install supplementary wiring harness for navigation in vehicles from production date 9/98 (PIN18 and PIN35 at connector of the ABS hydraulic unit assigned)

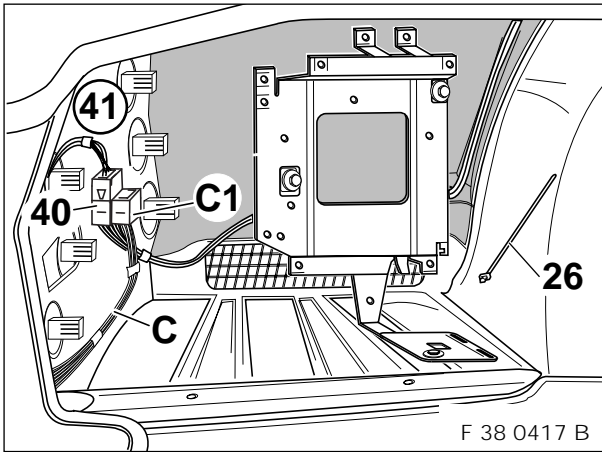

Clip in branch cable **C1**, black 6-pole pin housing, of the supplementary wiring harness for navigation **C** to the existing plug-in connector (40) at the taillight cup (41), rear left. Install supplementary wiring harness for navigation **C** along the closing panel to the right side part. Fasten supplementary wiring harness for navigation **C** with cable straps (26).

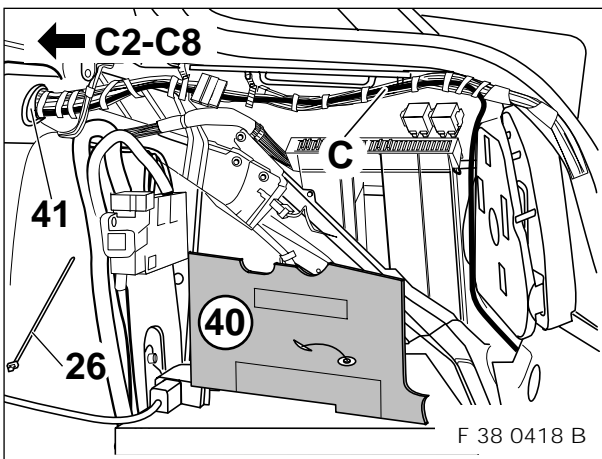

Dismantle insulating mat (40) in the right side part, rear. Install supplementary wiring harness for navigation **C**, as shown, to the lead-through grommet (41) in the rear window shelf. Then install branch cables **C2** to **C8** through the lead-through grommet (41) into the vehicle interior and from there along the right main cable loom to the installation location of the light module in the A-pillar on the right. Fasten supplementary wiring harness for navigation **C** with cable straps (26) and install insulating mat (40) again in the right side part, rear.

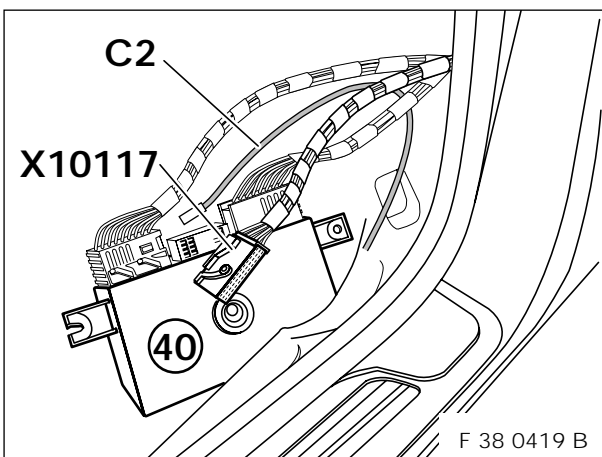

Dismantle light module (40), unpin the black 54-pole socket housing **X10117** from the light module (40) and open it. Plug in branch cable **C2**, 1-pole blade terminal contact, cable colour white/yellow, into **PIN38** of the black 54-pole socket housing **X10117**. Close black socket housing **X10117**, plug it in and reinstall light module (40). If necessary tie back excessive length of the supplementary wiring harness for navigation **C** before branch cable **C2**.

11. Install supplementary wiring harness for navigation in vehicles from production date 9/98 (PIN18 and PIN35 at connector of the ABS hydraulic unit assigned)

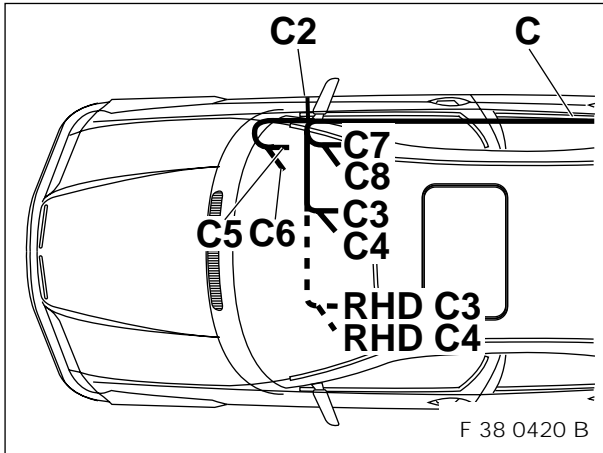

Insulate branch cables **C5** to **C8** of the supplementary wiring harness for navigation **C** with shrinkage tubing and tie back in the area of the right front sill.

In left-hand drive vehicles, install branch cables **C3** and **C4** of the supplementary wiring harness for navigation **C** to the joint connector box behind the glove box (excess length must be tied back) and connect to the joint connectors **X10183** and **X10184**.

In right-hand drive vehicles, install branch cables **C3** and **C4** of the supplementary wiring harness for navigation **C** behind the heater box to the left to the joint connector box behind the glove box and connect to the joint connectors **X10183** and **X10184**.

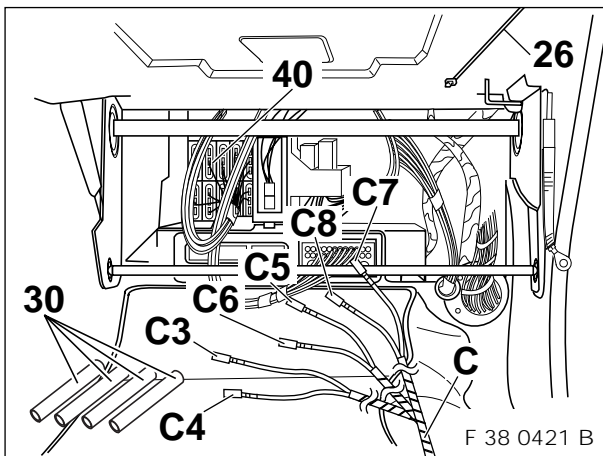

▶ Illustration shows the area behind the glove box in a left-hand drive vehicle. You should proceed in the identical sequence for right-hand drive vehicles. ◀

Push on a shrinkage tubing (30) for insulation in each case onto branch cable **C5**, 1-pole blade terminal contact, cable colour yellow/red, branch cable **C6**, 1-pole blade terminal contact, cable colour yellow/white, branch cable **C7**, 1-pole blade terminal contact, cable colour yellow/red, and branch cable **C8**, 1-pole blade terminal contact, cable colour yellow/white, of the supplementary wiring harness for navigation **C**, and shrink them on with hot-air dryer.

Then tie back branch cables **C5** to **C8** in the area of the right front sill with cable straps (26). Plug branch cable **C3**, 1-pole blade terminal contact, cable colour yellow/red, onto the joint connector **X10183** (cable colour at joint connector yellow/red) in the joint connector box (40) behind the glove box.

Plug branch cable **C4**, 1-pole blade terminal contact, cable colour yellow/white, onto the joint connector **X10184** (cable colour at joint connector yellow/white) in the joint connector box (26) behind the glove box.

Any excessive lengths of branch cables **C3** and **C4** should be tied back with cable straps (26).

12. Install supplementary wiring harness for navigation in vehicles from production date 9/98 (PIN18 assigned and PIN35 not assigned at connector of the ABS hydraulic unit)

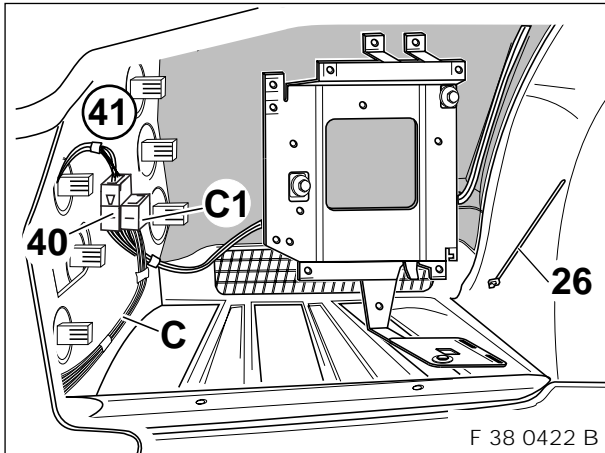

Clip in branch cable **C1**, black 6-pole pin housing, of the supplementary wiring harness for navigation **C** to the existing plug-in connector (40) at the taillight cup (41), rear left. Install supplementary wiring harness for navigation **C** along the closing panel to the right side part. Fasten supplementary wiring harness for navigation **C** with cable straps (26).

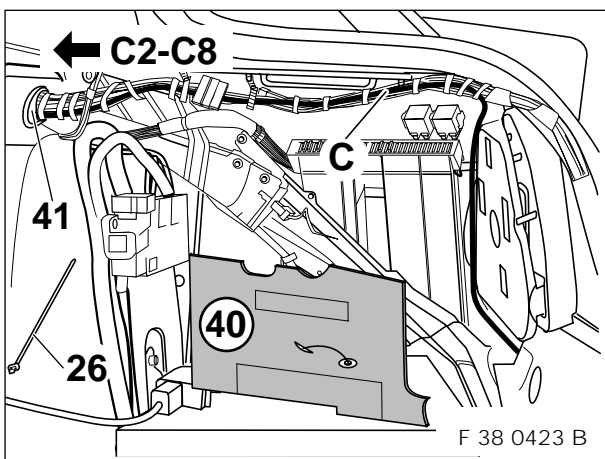

Dismantle insulating mat (40) in the right side part, rear. Install supplementary wiring harness for navigation **C**, as shown, to the lead-through grommet (41) in the rear window shelf. Then install branch cables **C2** to **C8** through the lead-through grommet (41) into the vehicle interior and from there along the right main cable loom to the installation location of the light module in the A-pillar on the right. Fasten supplementary wiring harness for navigation **C** with cable straps (26) and install insulating mat (40) again in the right side part, rear.

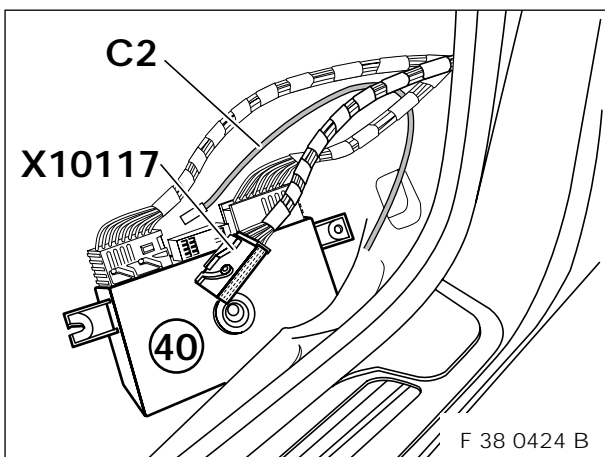

Dismantle light module (40), unpin the black 54-pole socket housing **X10117** from the light module (40) and open it. Plug in branch cable **C2**, 1-pole blade terminal contact, cable colour white/yellow, into **PIN38** of the black 54-pole socket housing **X10117**. Close black socket housing **X10117**, plug it in and reinstall light module (40). If necessary tie back excessive length of the supplementary wiring harness for navigation **C** before branch cable **C2**.

12. Install supplementary wiring harness for navigation in vehicles from production date 9/98 (PIN18 assigned and PIN35 not assigned at connector of the ABS hydraulic unit)

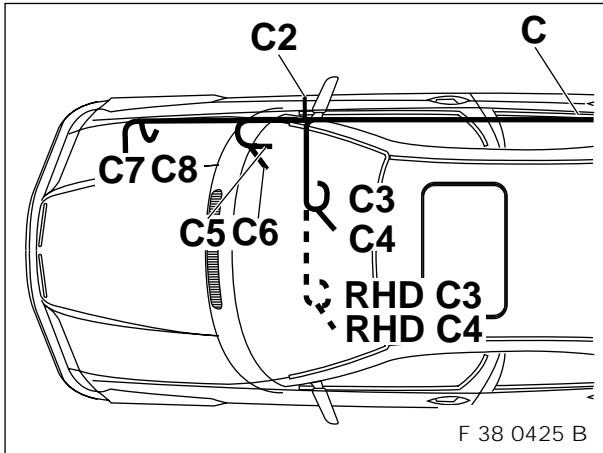

! Before further installation of the supplementary wiring harness for navigation **C**, you should remove the cover for the control unit box in the engine compartment, right. ◀

Install branch cables **C7** and **C8** of the supplementary wiring harness for navigation **C** through the lead-through grommet in the bulkhead, front right, into the control unit box and from there onwards to the hydraulic unit ABS.

Connect only branch cable **C7**, 1-pole blade terminal contact, to the black 42-pole connector **X1170** at **PIN35** of the hydraulic unit ABS.

Insulate branch cable **C8**, 1-pole blade terminal contact, with shrinkage tubing and tie it back. In left-hand drive vehicles, install branch cables **C3** and **C4** of the supplementary wiring harness for navigation **C** to the joint connector box behind the glove box.

In right-hand drive vehicles, install branch cables **C3** and **C4** of the supplementary wiring harness for navigation **C** behind the heater box to the left to the joint connector box behind the glove box.

Insulate branch cable **C3**, 1-pole blade terminal contact, with shrinkage tubing and tie it back.

Connect only branch cable **C4**, 1-pole blade terminal contact, to joint connector **X10184**.

Insulate branch cables **C5** and **C6** of the supplementary wiring harness for navigation **C** with shrinkage tubing and tie back in the area of the right front sill.

12. Install supplementary wiring harness for navigation in vehicles from production date 9/98 (PIN18 assigned and PIN35 not assigned at connector of the ABS hydraulic unit)

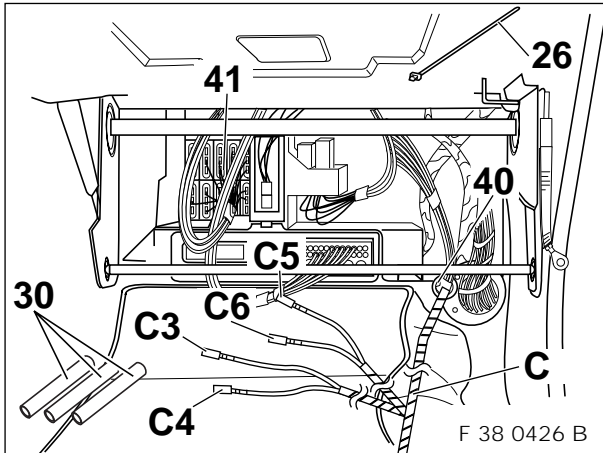

▶ Illustration shows the area behind the glove box in a left-hand drive vehicle. You should proceed in the identical sequence for right-hand drive vehicles. ◀

Feed the supplementary wiring harness for navigation **C** with branch cables **C7** and **C8** through the lead-through grommet (40) in the bulkhead, front right, to the control unit box in the engine compartment and fasten with cable straps (26).

Push on a shrinkage tubing (30) for insulation in each case onto branch cable **C3**, 1-pole blade terminal contact, cable colour yellow/red, branch cable **C5**, 1-pole blade terminal contact, cable colour yellow/red, and branch cable **C6**, 1-pole blade terminal contact, cable colour yellow/white, of the supplementary wiring harness for navigation **C**, and shrink them on with hot-air dryer.

Plug branch cable **C4**, 1-pole blade terminal contact, cable colour yellow/white, onto the joint connector **X10184** (cable colour at joint connector yellow/white) in the joint connector box (41) behind the glove box.

Then tie back branch cables **C3**, **C5** and **C6** in the area of the right front sill with cable straps (26).

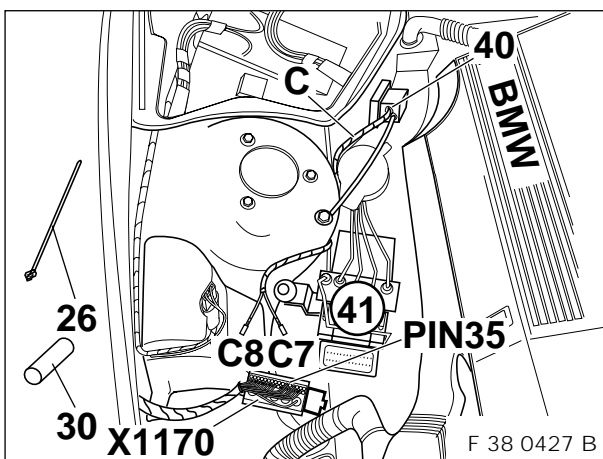

Push supplementary wiring harness for navigation **C** with branch cables **C7** and **C8** carefully through the rubber grommet (40) and install to the hydraulic unit ABS (41).

▶ Seal the rubber grommet (40) with silicon (splash-water protection) after installation of the supplementary wiring harness for navigation **C**. ◀

Decouple the black 42-pole connector **X1170** of the hydraulic unit ABS and connect branch cable **C7** as follows:

Pin in branch cable **C7**, 1-pole blade terminal contact, cable colour yellow/red, into the black 42-pole connector **X1170** of the hydraulic unit ABS in plug-in place **PIN35**.

Push onto branch cable **C8**, 1-pole blade terminal contact, cable colour yellow/white, a shrinkage tubing (30) for insulation and shrink it on with a hot-air dryer.

Couple black 42-pole connector **X1170** again and plug onto hydraulic unit ABS.

Then fasten supplementary wiring harness for navigation **C** in the area of the engine compartment with cable straps (26).

13. Install supplementary wiring harness for navigation in vehicles from production date 9/98 (PIN18 not assigned and PIN35 assigned at connector of the ABS hydraulic unit)

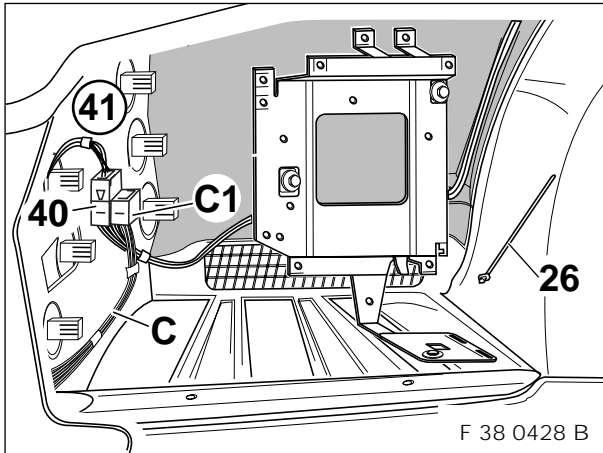

Clip in branch cable **C1**, black 6-pole pin housing, of the supplementary wiring harness for navigation **C** to the existing plug-in connector (40) at the taillight cup (41), rear left. Install supplementary wiring harness for navigation **C** along the closing panel to the right side part. Fasten supplementary wiring harness for navigation **C** with cable straps (26).

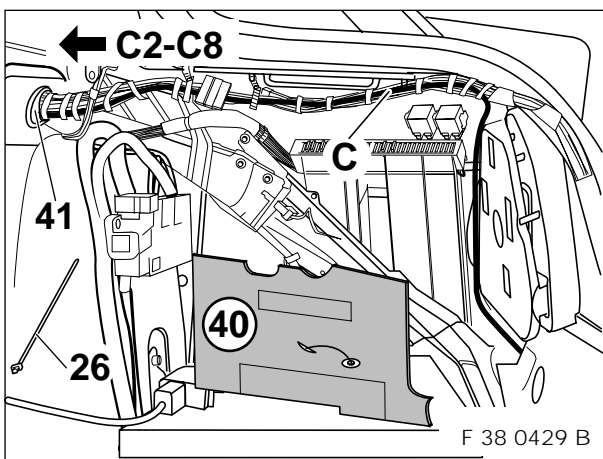

Dismantle insulating mat (40) in the right side part, rear. Install supplementary wiring harness for navigation **C**, as shown, to the lead-through grommet (41) in the rear window shelf. Then install branch cables **C2** to **C8** through the lead-through grommet (41) into the vehicle interior and from there along the right main cable loom to the installation location of the light module in the A-pillar on the right. Fasten supplementary wiring harness for navigation **C** with cable straps (26) and install insulating mat (40) again in the right side part, rear.

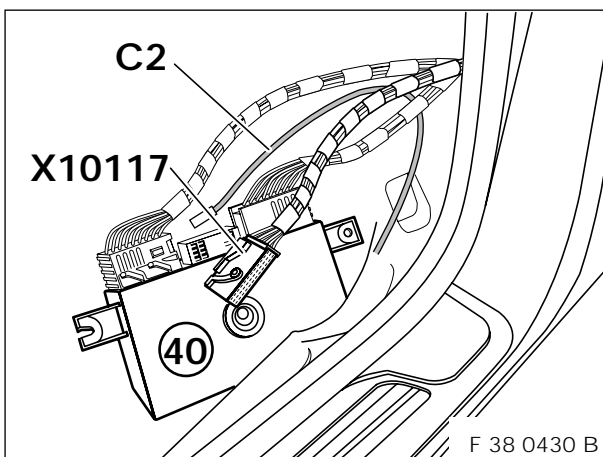

Dismantle light module (40), unpin the black 54-pole socket housing **X10117** from the light module (40) and open it. Plug in branch cable **C2**, 1-pole blade terminal contact, cable colour white/yellow, into **PIN38** of the black 54-pole socket housing **X10117**. Close black socket housing **X10117**, plug it in and reinstall light module (40). If necessary tie back excessive length of the supplementary wiring harness for navigation **C** before branch cable **C2**.

13. Install supplementary wiring harness for navigation in vehicles from production date 9/98 (PIN18 not assigned and PIN35 assigned at connector of the ABS hydraulic unit)

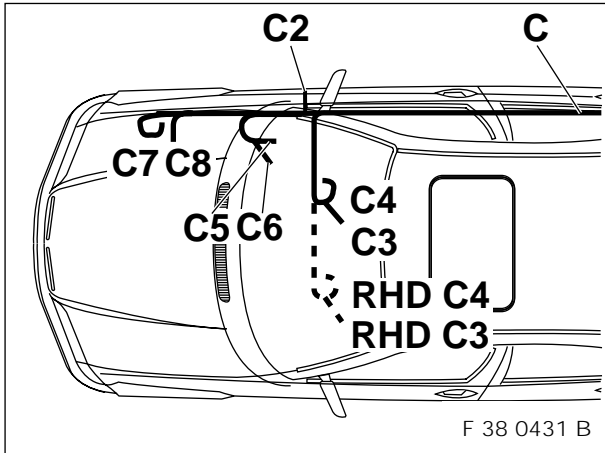

! Before further installation of the supplementary wiring harness for navigation **C**, you should remove the cover for the control unit box in the engine compartment, right. ◀

Install branch cables **C7** and **C8** of the supplementary wiring harness for navigation **C** through the lead-through grommet in the bulkhead, front right, into the control unit box and from there onwards to the hydraulic unit ABS.

Insulate branch cable **C7**, 1-pole blade terminal contact, with shrinkage tubing and tie it back. Connect only branch cable **C8**, 1-pole blade terminal contact, to the black 42-pole connector **X1170** at **PIN18** of the hydraulic unit ABS.

In left-hand drive vehicles, install branch cables **C3** and **C4** of the supplementary wiring harness for navigation **C** to the joint connector box behind the glove box.

In right-hand drive vehicles, install branch cables **C3** and **C4** of the supplementary wiring harness for navigation **C** behind the heater box to the left to the joint connector box behind the glove box. Connect only branch cable **C3**, 1-pole blade terminal contact, to joint connector **X10183**.

Insulate branch cable **C4**, 1-pole blade terminal contact, with shrinkage tubing and tie it back.

Insulate branch cables **C5** and **C6** of the supplementary wiring harness for navigation **C** with shrinkage tubing and tie back in the area of the right front sill.

13. Install supplementary wiring harness for navigation in vehicles from production date 9/98 (PIN18 not assigned and PIN35 assigned at connector of the ABS hydraulic unit)

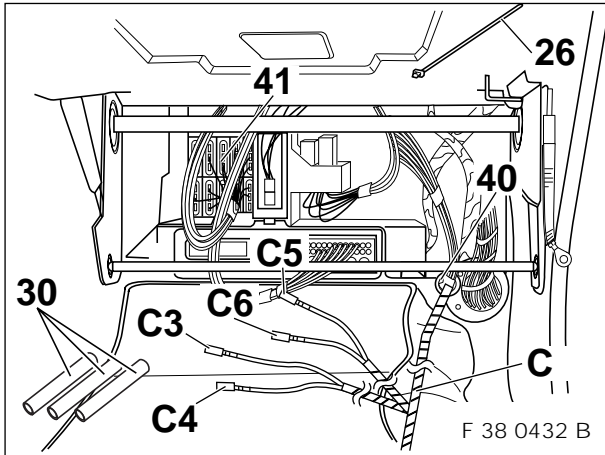

▶ Illustration shows the area behind the glove box in a left-hand drive vehicle. You should proceed in the identical sequence for right-hand drive vehicles. ◀

Feed the supplementary wiring harness for navigation **C** with branch cables **C7** and **C8** through the lead-through grommet (40) in the bulkhead, front right, to the control unit box in the engine compartment and fasten with cable straps (26).

Push on a shrinkage tubing (30) for insulation in each case onto branch cable **C4**, 1-pole blade terminal contact, cable colour yellow/white, branch cable **C5**, 1-pole blade terminal contact, cable colour yellow/red, and branch cable **C6**, 1-pole blade terminal contact, cable colour yellow/white, of the supplementary wiring harness for navigation **C**, and shrink them on with hot-air dryer.

Plug branch cable **C3**, 1-pole blade terminal contact, cable colour yellow/red, onto the joint connector **X10183** (cable colour at joint connector yellow/red) in the joint connector box (41) behind the glove box.

Then tie back branch cables **C4**, **C5** and **C6** in the area of the right front sill with cable straps (26).

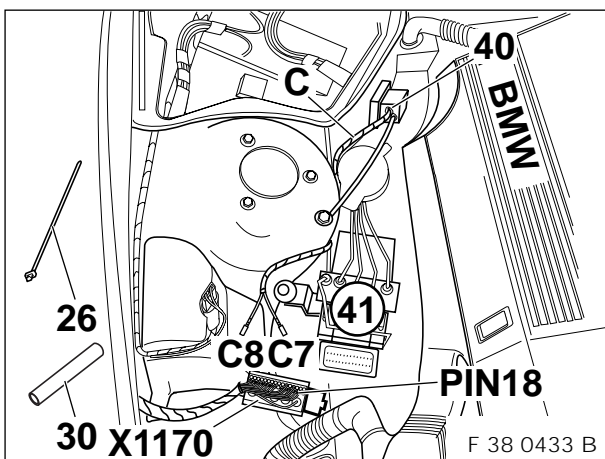

Push supplementary wiring harness for navigation **C** with branch cables **C7** and **C8** carefully through the rubber grommet (40) and install to the hydraulic unit ABS (41).

▶ Having installed the supplementary wiring harness for navigation **C**, seal the rubber grommet (40) with silicon (splash-water protection). ◀

Decouple the black 42-pole connector **X1170** of the hydraulic unit ABS and connect branch cable **C8** as follows:

Pin in branch cable **C8**, 1-pole blade terminal contact, cable colour yellow/white, into the black 42-pole connector **X1170** of the hydraulic unit ABS in plug-in place **PIN18**.

Push onto branch cable **C7**, 1-pole blade terminal contact, cable colour yellow/red, a shrinkage tubing (30) for insulation and shrink it on with a hot-air dryer.

Couple black 42-pole connector **X1170** again and plug onto hydraulic unit ABS.

Then fasten supplementary wiring harness for navigation **C** in the area of the engine compartment with cable straps (26).

14. Install navigation system

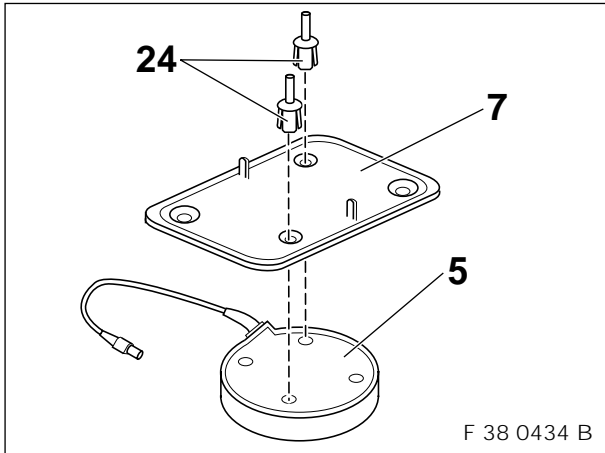

Place retaining plate (7) on the GPS antenna (5) and attach it with expanding rivets (24).

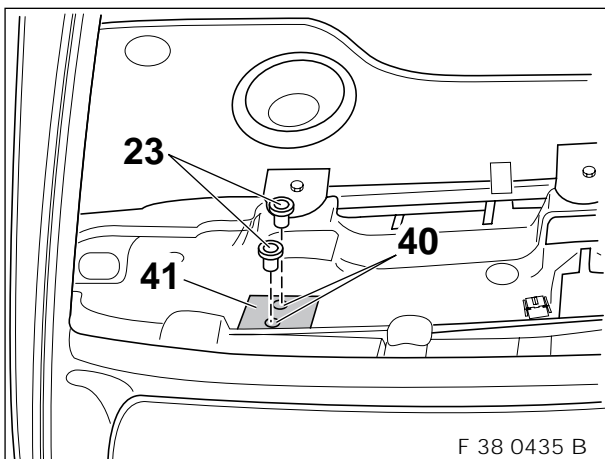
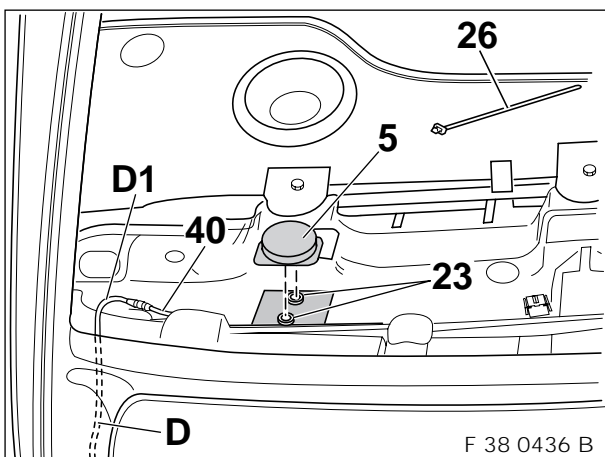

Illustration shows rear window shelf, left. ◀

Check that existing attachments points (40) are \varnothing 8 mm.
If necessary rebores attachment points to \varnothing 8 mm.
Take out pre-punched cut-out (41) under the rear window shelf and press in attachment grommets (23) into the attachment points (40).



Plug together branch cable **D1**, coaxial pin housing, of the antenna extension for GPS antenna **D**, with the antenna cable (40) of the GPS antenna (5).
Insert retaining plate with mounted GPS antenna into the attachment grommets (23) and install antenna extension for GPS antenna **D** along the original wiring harness to the designated installation location of the navigation computer (in the boot, rear left above) and fasten with cable straps (26).

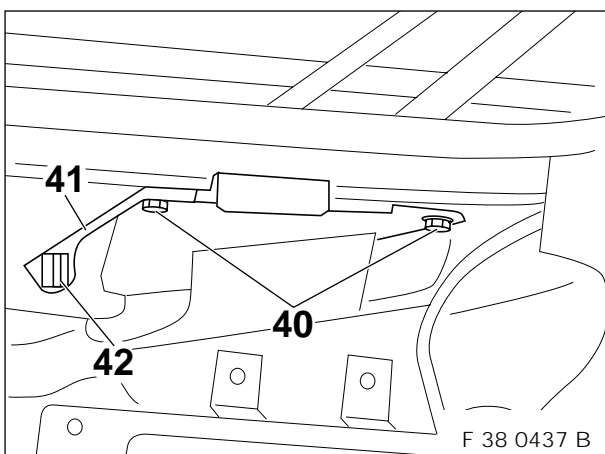
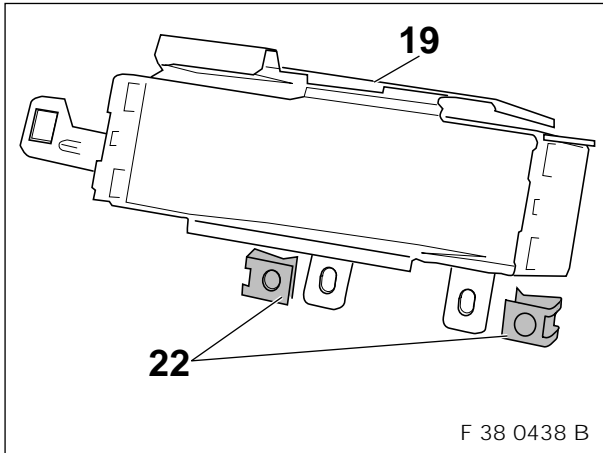

Illustration shows boot, rear left above. ◀

Remove retaining nuts M6 (40) and dismantle installed trim-panel bracket (41) (is no longer required).
Remove retaining clip (42) from the trim-panel bracket (41).
Retaining nuts M6 (40) and retaining clip (42) are to be further used when installing the bracket of the navigation computer.

14. Install navigation system



Put plug-in nuts M5 (22) on to the bracket for the navigation computer (19).

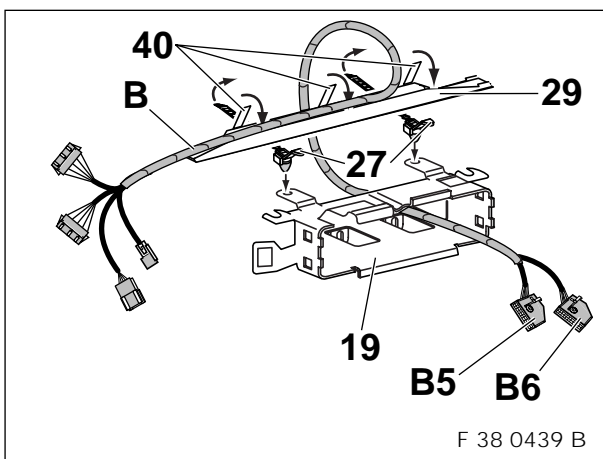

Place navigation wiring harness **B**, as shown, in the supplied cable duct (29) and close all tabs (40).

Insert both AW cable straps (27) in the bracket for navigation computer (19).

Place cable duct (29), as shown, in the AW cable straps (27) and close the AW cable straps (27).

Push branch cable **B5**, blue 18-pole socket housing, and branch cable **B6**, Bordeaux-coloured 18-pole socket housing, of the navigation wiring harness **B**, through the bracket of the navigation computer (19).

14. Install navigation system

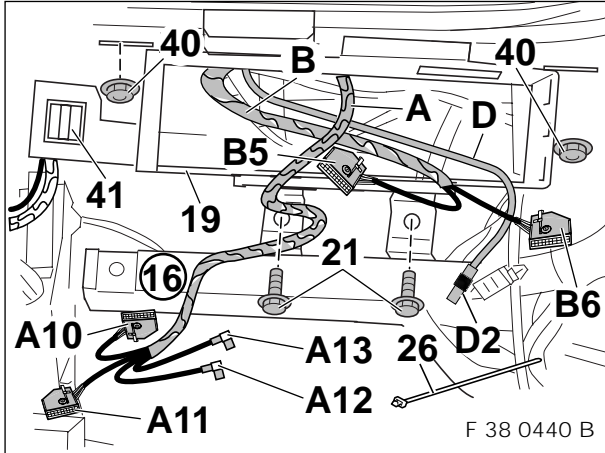

Illustration shows boot, rear left above. ◀

Separate off the pre-punched cut-out in the insulating mat in the side part, rear left. Loosen the basic carrier (16) somewhat in order to be able to install the bracket of the navigation computer (19).

Slide in bracket of navigation computer (19) with its pre-mounted navigation wiring harness **B** and screw it on with the existing nuts M6 (49) and the hexagon bolts with washers M5x14 (21).

Insert existing removed retaining clip (41) in the bracket of the navigation computer (19).

Then push branch cables **A10** to **A13** of the on-board monitor wiring harness **A**, and branch cable **D2**, coaxial socket housing, of the antenna extension for GPS antenna **D**, through the bracket of the navigation computer (19).



Tie back branch cable **A10**, white 18-pole socket housing, branch cable **A12**, angled coaxial socket housing, and branch cable **A13**, angled coaxial socket housing, of the on-board monitor wiring harness **A** with cable straps (26) to the on-board monitor wiring harness **A**.

Tie back branch cable **B5**, blue 18-pole socket housing, of the navigation wiring harness **B**, also with cable strap (26) to the navigation wiring harness **B**. ◀

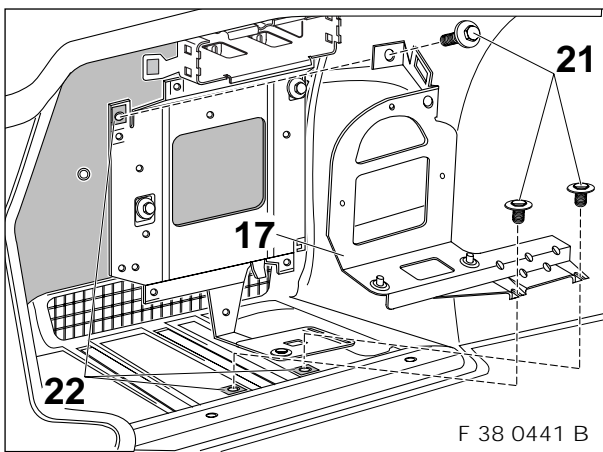

Put three plug-in nuts M5 (22) on at the designated places and screw the bracket of the video module (17) to the plug-in nuts M5 (22) with three hexagon bolts with washers M5x14 (21).

14. Install navigation system

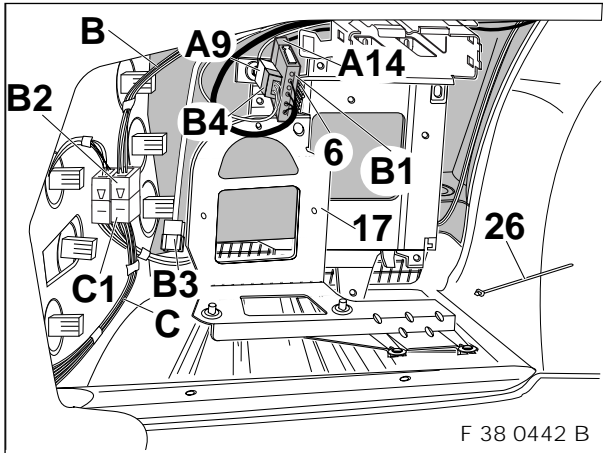

Engage the retaining clip (6) with the clipped-in branch cables **A9**, black 10-pole pin housing, and **A14**, natural-coloured 6-pole pin housing, of the on-board monitor wiring harness **A** to the bracket of the video module (17).

Plug branch cable **B2**, black 6-pole socket housing, of the navigation wiring harness **B**, onto branch cable **C1**, black 6-pole pin housing, of the supplementary cable for navigation **C**.

Plug branch cable **B1**, natural-coloured 6-pole socket housing, of the navigation wiring harness **B**, onto branch cable **A14**, natural-coloured 6-pole pin housing, of the on-board monitor wiring harness **A**.

Plug branch cable **B4**, black 10-pole socket housing, of the navigation wiring harness **B**, onto branch cable **A9**, black 10-pole pin housing, of the on-board monitor wiring harness **A**.



Additional installed wiring harness should be fasten with cable straps (26) to the original wiring harness. ◀



In vehicles which are equipped with Basic Interface Telephone 2 (BIT2), plug together branch cable **B3**, black 6-pole pin housing, of the navigation wiring harness **B**, with the black 6-pole socket housing of the Basic Interface Telephone (BIT2) wiring harness.

In vehicles without Basic Interface Telephone 2 (BIT2), insulate and tie back branch cable **B3**, black 6-pole pin housing, of the navigation wiring harness **B**. ◀

14. Install navigation system

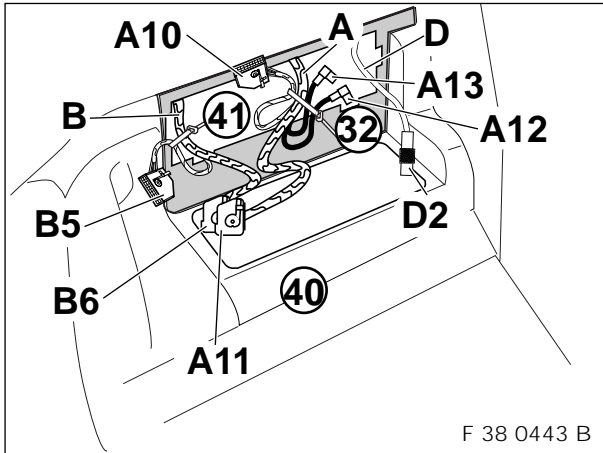

Cut out supplied template (32) and place it on the boot trim panel, left (40). Mark cut-out for navigation computer (41) and make cut-out in the boot trim panel, left (40). Then install boot trim panel, left (40).

▶ Feed out through the aperture for the navigation computer (41) branch cable A11, blue 18-pole socket housing, of the on-board monitor wiring harness **A**, with the tied back branch cables **A10**, **A12** and **A13**, as well as branch cable **B6**, Bordeaux-coloured 18-pole socket housing, of the navigation wiring harness **B**, with the tied-back branch cable **B5** and branch cable **D2**, coaxial socket housing, of the antenna extension for the GPS antenna **D**. ◀

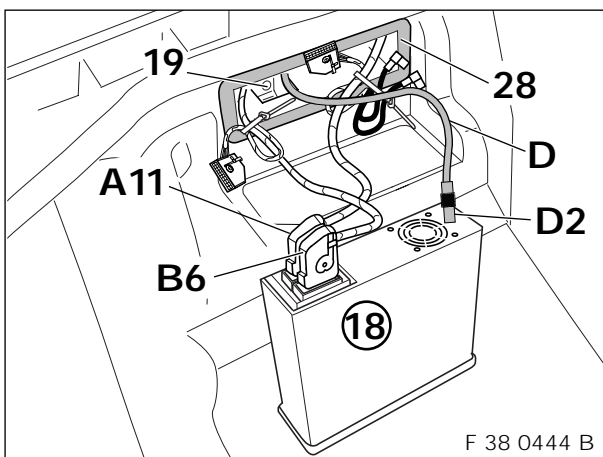

Push in cover frame (28) into the aperture until all detents in the bracket of the navigation computer (19) have engaged.

Plug in branch cable **A11**, blue 18-pole socket housing, of the on-board monitor wiring harness **A**, into the blue 18-pole pin housing of the navigation computer (18). Plug in branch cable **B6**, Bordeaux-coloured 18-pole socket housing, of the navigation wiring harness **B**, into the Bordeaux-coloured 18-pole pin housing of the navigation computer (18). Plug in branch cable **D2**, coaxial socket housing, of the antenna extension for GPS antenna **D**, into coaxial pin housing of the navigation computer (18).

⚠ Make sure that the cables or leads behind the navigation computer are not jammed or damaged. ◀

Then insert the navigation computer (18) in the cover frame (28) and engage it.

15. Coding and finalising operations



If the video module and TV amplifiers for TV function are to be fitted additionally in the vehicle, the **Coding** and **Finalising operations** should be carried out after the video module and TV amplifiers for TV function have been fitted. ◀

Coding

This system is coding-relevant.

So that the retrofit system

- is fully functional and
- in association with the other electrical vehicle systems excludes malfunctions and faults, a coding of this retrofit system, and if necessary other vehicle components, must be carried out and stored in the central coding key of the IKE.

This coding is carried out automatically with the respective current coding programme in the **"Retrofit"** path.

The sequence is operator-guided and you should note the relevant text instructions when carrying out the individual steps.

Procedure:

- Connect DIS/MoDIC to the vehicle
- Ignition **"ON"**
- Selection **"Coding ZCS"**
- Confirm input data with **"Y"** (only with MoDIC)
- Series: **"E38"**
- Path: **"2 Retrofit"**
- System: **"8 Navigation"**



A **"Navigation CD-ROM Operating software V16"** is necessary for loading the operating system.

Caution! Do not put the CD-ROM **"Operating software"** yet in the CD drive! Put the CD-ROM **"Operating software"** in only when told to do so on the on-board monitor. The language coding is carried out simultaneously with this CD-ROM **"Operating software"**. ◀

- Start automatic coding (confirm with **"Y"**)
- Follow the instructions on the on-board monitor
- Print out new master label of the changed coding key and stick it in the vehicle boot on the right in the area of the battery
- After the message **"Coding ended"** on the screen of the DIS/MoDIC, ignition **"OFF"**, wait for at least 10 seconds and then ignition **"ON"** again.
- Print out error memory
- Insert CD-ROM **"Road map"** in the navigation computer
- Carry out function test.

15. Coding and finalising operations



In vehicles with DSP amplifier, the DSP amplifier must be newly coded in addition. ◀

Procedure:

- Connect DIS/MoDIC to the vehicle
- Ignition **"ON"**
- Selection **"Coding ZCS"**
- Confirm input data with **"Y"** (only with MoDIC)
- Series: **"E38"**
- Path: **"1 Recoding"**
- System: **"82 DSP "**
- Start automatic coding (confirm with **"Y"**)
- After the message **"Coding ended"** on the screen of the DIS/MoDIC, ignition **"OFF"**, wait for at least 10 seconds and then ignition **"ON"** again.
- Print out error memory
- Carry out function test.

Language coding

The language coding can be carried out again via the **"Navigation CD-ROM Operating software V16"**.

Finalising operations

Connect battery
Carry out function test
Print out error memory
Reassemble the vehicle in the reverse order of disassembly.

16. Connection description for TV function



This chapter should only be taken note of if the vehicle is to be additionally equipped with TV function. ◀

To be in a position to equip the vehicle with TV function, the necessary parts (video module, TV amplifiers, small parts) have to be ordered separately with reference to the Electronic Parts Catalogue (EPC) and fitted.

The relevant branch cables of the wiring harnesses have to be connected also as follows:

Undo the tied-back branch cable **A4**, angled coaxial socket housing, of the on-board monitor wiring harness **A**, and plug it on to the previously mounted left TV amplifier in the left C-pillar. Undo the tied-back branch cable **A13**, angled coaxial socket housing, of the on-board monitor wiring harness **A**, and plug it on to the previously mounted right TV amplifier in the right C-pillar.

Unplug branch cable **A11**, blue 18-pole socket housing of the on-board monitor wiring harness **A** from the navigation computer.

Undo the blue 18-pole socket housing tied back to branch cable **B5** of the the navigation wiring harness **B**, and plug it into the blue 18-pole pin housing at the navigation computer.

Undo branch cables **A10**, white 18-pole socket housing, **A12**, angled coaxial socket housing and **A13**, angled coaxial socket housing (all tied back to the on-board monitor wiring harness **A**).

Then install branch cables **A10** to **A13** to the video module and plug into the video module as follows:

Plug in branch cable **A10**, white 18-pole socket housing, at white 18-pole pin housing of the video module.

Plug in branch cable **A11**, blue 18-pole socket housing, at blue 18-pole pin housing of the video module.

Plug in branch cable **A12** and **A13**, angled coaxial socket housing, at the two coaxial pin housings of the video module.



Should the vehicle be equipped at a later date with TV function, the system must be newly coded. For coding see Chapter 15 "**Coding and finalising operations**". ◀

17. Circuit diagram, on-board monitor wiring harness

Key

A196	On-board monitor
A197	Video module
N9	Radio
X581	Connector speedo A
X1290	Connector 30A69
X1291	Connector RA46
X1436	Connector 58g
X1532	Radio/HiFi navigation
X1804	Plug-in connector navigation - video module
X6500	Plug-in connector adapter
X13016	Earth stereo/HiFi
X18126	Radio A
X18344	Connector I-Bus
X18801	On-board monitor operating unit
X18802	On-board monitor
X18804	Video module A
X18805	Radio B
X18806	Video module B

Colour abbreviations

BR =	brown
RT =	red
VI =	violet
WS =	white
GR =	grey
SW =	black
GN =	green
GE =	yellow

18. Circuit diagram, navigation system wiring harness

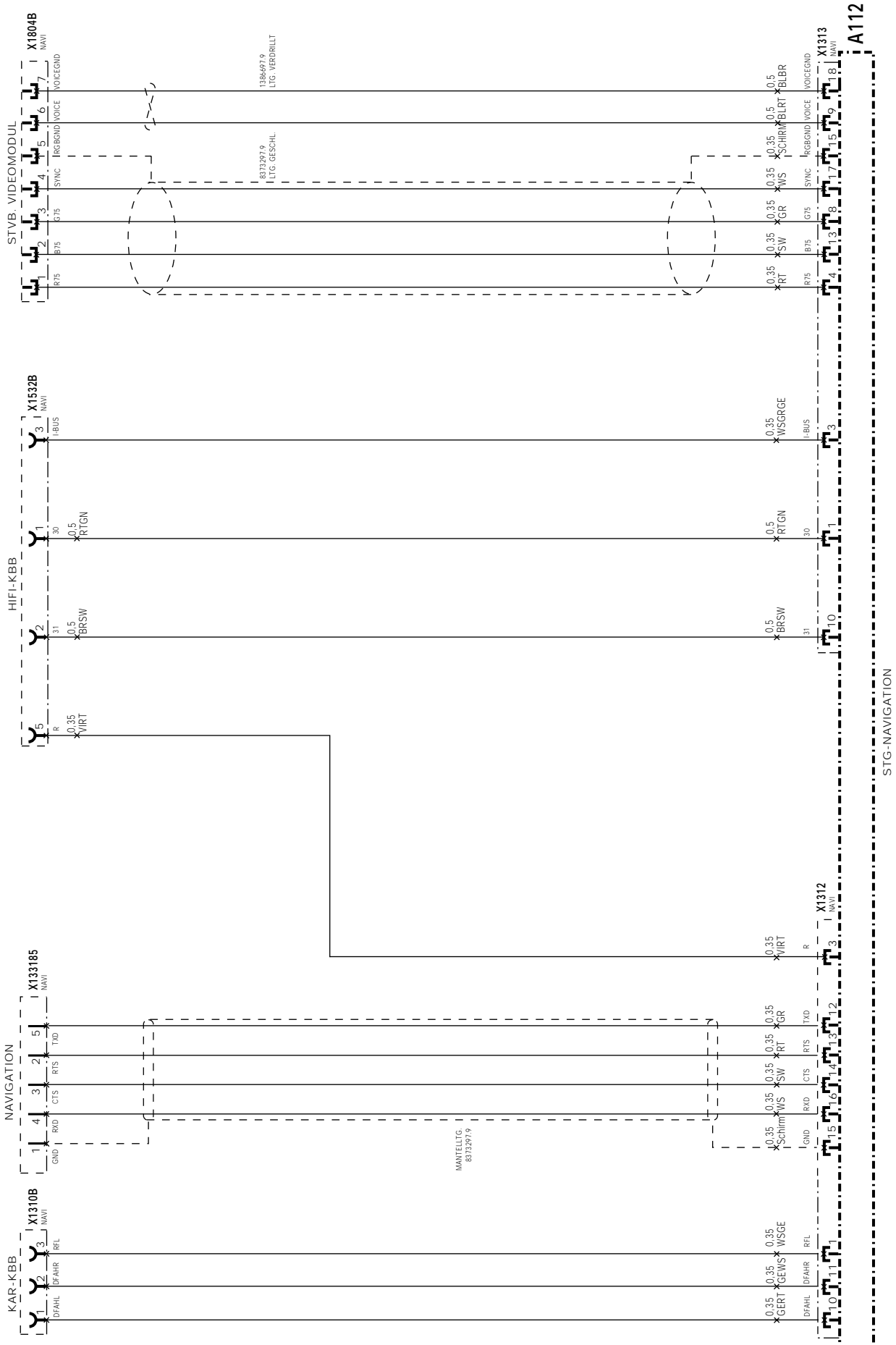

F 38 0447 B

18. Circuit diagram, navigation system wiring harness

Key

A112	Plug-in connector, navigation
X13010	KAR navigation
X1312	Navigation A
X1313	Navigation B
X1532	Radio/HiFi-navigation
X1804	Plug-in connector navigation-video module
X13318	Navigation/telephone

Colour abbreviations

BR =	brown
RT =	red
VI =	violet
WS =	white
GR =	grey
SW =	black
GN =	green
GE =	yellow

19. Circuit diagram, supplementary wiring harness for navigation system

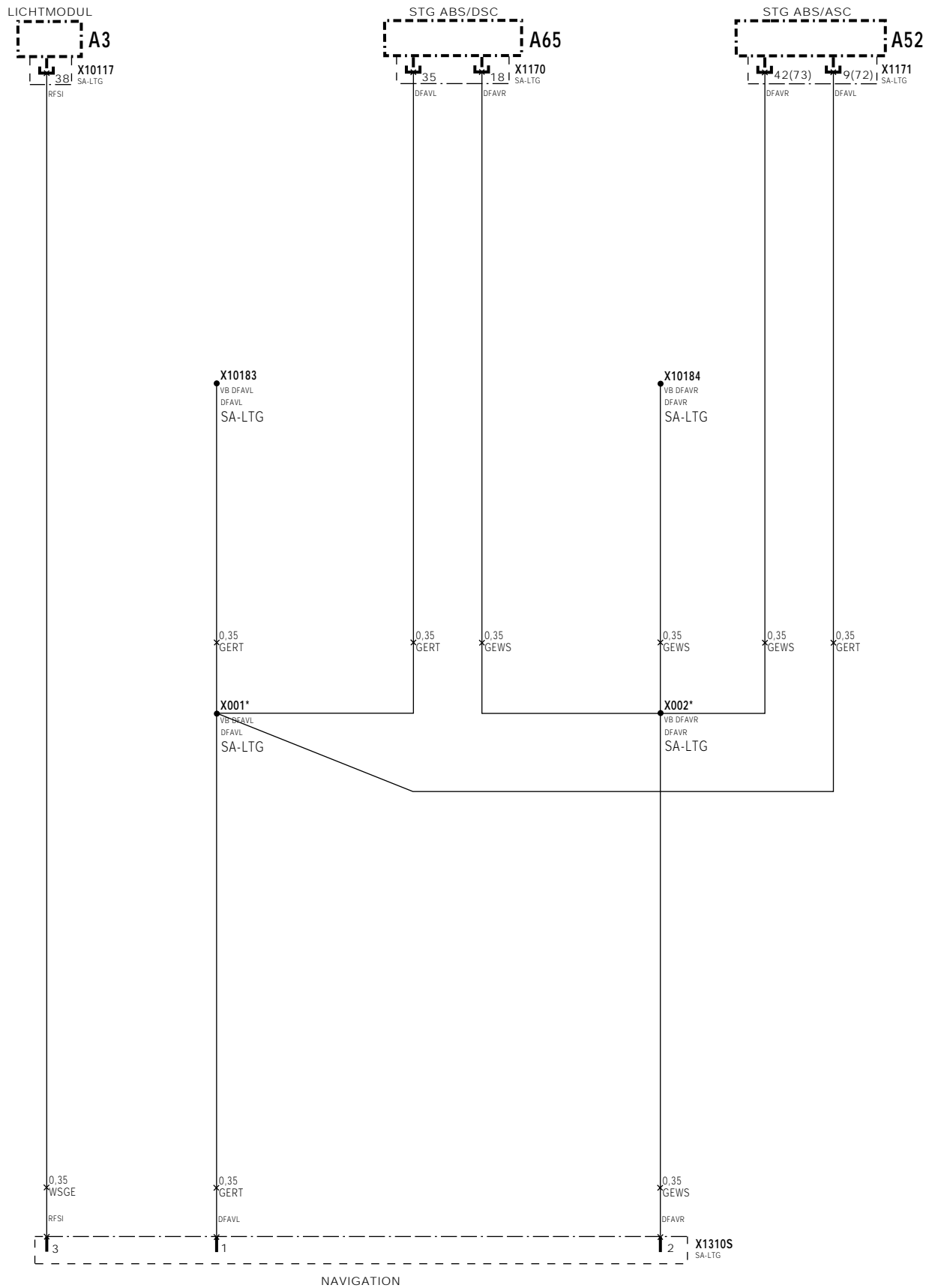

19. Circuit diagram, supplementary wiring harness for navigation system

Key

A3	Light module
A52	Hydraulic unit ABS/ASC
A65	Hydraulic unit ABS/DSC
X001*	Connector DFAVL
X002*	Connector DFAVR
X1170	ABS/DSC
X1171	ABS/ASC
X1310	KAR navigation
X10117	black 54-pole socket housing of the light module
X10183	Joint connector DFAVL
X10184	Joint connector DFAVR

In automatic vehicles with M62 B44 engine and DSC, from production date 9/97 to production date 9/98, the DFAVL signal is lies on PIN72 and the DFAVR signal on PIN73 of the ABS/ASC control unit connector X1171.

The items marked * are only valid for this diagram. All other items and X-designations correspond to the BMW customer service circuit diagrams.

Colour abbreviations

BR =	brown
RT =	red
VI =	violet
WS =	white
GR =	grey
SW =	black
GN =	green
GE =	yellow